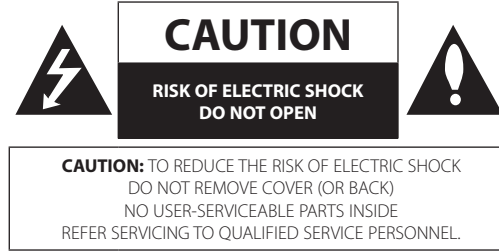

# OWNER'S MANUAL

## Network Dome Camera

Please read this manual carefully before operating your set and retain it for future reference.

MODEL  
LW9422 series

This lightning flash with arrowhead symbol within an equilateral triangle is intended to alert the user to the presence of uninsulated dangerous voltage within the product's enclosure that may be of sufficient magnitude to constitute a risk of electric shock to persons.



The exclamation point within an equilateral triangle is intended to alert the user to the presence of important operating and maintenance (servicing) instructions in the literature accompanying the product.

**FCC WARNING:** This equipment may generate or use radio frequency energy. Changes or modifications to this equipment may cause harmful interference unless the modifications are expressly approved in the instruction manual. The user could lose the authority to operate this equipment if an unauthorized change or modification is made.

**REGULATORY INFORMATION: FCC Part 15**

This equipment has been tested and found to comply with the limits for a Class A digital device, pursuant to Part 15 of the FCC Rules. These limits are designed to provide reasonable protection against harmful interference when the equipment is operated in a commercial environment. This equipment generates, uses, and can radiate radio frequency energy and, if not installed and used in accordance with the instruction manual, may cause harmful interference to radio communications.

Operation of this equipment in a residential area is likely to cause harmful interference in which case the user will be required to correct the interference at his own expense.

- A suitable conduit entries, knock-outs or glands shall be provided in the cable entries of this product in the end user.
- Caution: Danger of explosion if battery is incorrectly replaced. Replaced only with the same or equivalent type recommended by the manufacturer. Dispose of used batteries according to the manufacturer's instructions.
- Holes in metal, through which insulated wires pass, shall have smooth well rounded surfaces or shall be provided with brushings.

This Class A digital apparatus complies with Canadian ICES-003.  
Cet appareil numérique de la classe A est conforme à la norme NMB-003 du Canada.

**Warning**

- Do not install this equipment in a confined space such as a bookcase or similar unit.
- Wiring methods shall be in accordance with the National Electric Code, ANSI/NFPA 70.
- This is a class A product. In a domestic environment this product may cause radio interference in which case the user may be required to take adequate measures.
- To reduce a risk of fire or electric shock, do not expose this product to rain or moisture.

**Caution**

- This installation should be made by a qualified service person and should conform to all local codes.
- To avoid electrical shock, do not open the cabinet. Refer servicing to qualified personnel only.
- The apparatus shall not be exposed to water (dripping or splashing) and no objects filled with liquids, such as vases, shall be placed on the apparatus.

To disconnect power from mains, pull out the mains cord plug. When installing the product, ensure that the plug is easily accessible.



LG Electronics hereby declares that this/these product(s) is/are in compliance with the essential requirements and other relevant provisions of Directive 2004/108/EC, 2006/95/EC, and 2009/125/EC.  
European Standards Centre:  
Krijgsman 1, 1186 DM  
Amstelveen The Netherlands

**Disposal of your old appliance**



1. When this crossed-out wheeled bin symbol is attached to a product it means the product is covered by the European Directive 2002/96/EC.
2. All electrical and electronic products should be disposed of separately from the municipal waste stream via designated collection facilities appointed by the government or the local authorities.
3. The correct disposal of your old appliance will help prevent potential negative consequences for the environment and human health.
4. For more detailed information about disposal of your old appliance, please contact your city office, waste disposal service or the shop where you purchased the product.

EEE Compliance with Directive. (for Turkey only)

**Important Safety Instructions**

1. Read these instructions.
2. Keep these instructions.
3. Heed all warnings.
4. Follow all instructions.
5. Do not use this apparatus near water.
6. Clean only with dry cloth.
7. Do not block any ventilation openings. Install in accordance with the manufacturer's instructions.

8. Do not install near any heat sources such as radiators, heat registers, stoves, or other apparatus (including amplifiers) that produce heat.
9. Do not defeat the safety purpose of the polarized or grounding-type plug. A polarized plug has two blades with one wider than the other. A grounding type plug has two blades and a third grounding prong. The wide blade or the third prong are provided for your safety. If the provided plug does not fit into your outlet, consult an electrician for replacement of the obsolete outlet.
10. Protect the power cord from being walked on or pinched particularly at plugs, convenience receptacles, and the point where they exit from the apparatus.
11. Only use attachments/accessories specified by the manufacturer.
12. Use only with the cart, stand, tripod, bracket, or table specified by the manufacturer, or sold with the apparatus. When a cart is used, use caution when moving the cart/apparatus combination to avoid injury from tip-over.



13. Unplug this apparatus during lightning storms or when unused for long periods of time.
14. Refer all servicing to qualified service personnel. Servicing is required when the apparatus has been damaged in any way, such as power-supply cord or plug is damaged, liquid has been spilled or objects have fallen into the apparatus, the apparatus has been exposed to rain or moisture, does not operate normally, or has been dropped.

**Handling of the unit**

Be careful not to spill water or other liquids on the unit. Be cautious not to get combustible or metallic material inside the body. If used with foreign matter inside, the camera is liable to fail or to get cause of fire or electric shock.

- Remove dust or dirt on the surface of the lens with a blower.
- Use a dry soft cloth to clean the body. If it is very dirty, use a cloth dampened with a small quantity of neutral detergent then wipe dry.
- Avoid the use of volatile solvents such as thinners, alcohol, benzene and insecticides. They may damage the surface finish and/or impair the operation of the camera.

**Operating and storage location**

Avoid viewing a very bright object (such as light fittings) during an extended period. Avoid operating or storing the unit in the following locations.

- Extremely hot or cold places (operating temperature -10 °C to 50 °C, however, we recommend that the unit be used within a temperature range of 0 °C to 45 °C)
- Damp or dust place
- Places exposed to rain
- Places subject to strong vibration
- Close to generators of powerful electromagnetic radiation such as radio or TV transmitters.

**Specifications**

Item	LW9422 Series
Image Sensor	6.49 mm (1/2.8 Type) CMOS Sensor
Total Pixels	1 920(H) X 1 080(V), 2M
Lens	F1.6(Wide) to F2.1(Tele), f=5.3 to 63.6mm x12 Optical Zoom, x12 Digital Zoom
Day&Night	ICR Day & Night (Day / Night / Auto)
Minimum Illumination (30IRE)	Color 1 lx (AGC High, Sens-up Off)
	B/W 0.1 lx (AGC High, Sens-up Off)
White Balance	Auto / ATW / One Push / Manual
Shutter Speed	1/160 to 1/10 000
Iris	Auto / Manual
BLC	Off / WDR/ BLC
3D-DNR	OFF / LOW / MIDDLE / HIGH
AGC	OFF / LOW / MIDDLE / HIGH
Privacy Mask	8 Masks
Multi-Streaming	Dual Streaming
Video Out	1xBNC
Resolution (Maximum)	Up to 1 920 x 1 080
Frame Rate (Maximum)	30 fps @ 1 080p (1 920 x 1 080)
Bit Rate	256 kbps to 10 240 kbps
Audio Compression	G.711, G.726
Audio In/Out	1/1
Sample Rate	8 KHz
Audio Bit Rate	G.711: 64 kbps, G.726: 24 kbps, 32 kbps
Ethernet	10/100 Ethernet
Protocol	TCP/IP, UDP, Multicast, DHCP, SMTP, HTTP, SNMP, RTP, RTSP

Remote S/W	LG Ipsolute VMS or Web Client	
Pan/Tilt	Travel Range	Pan:360°(Endless), Tilt:180°
	Speed	Preset 500°/second
		Jog 0.1° to 360°/second
	Preset	128
	Pattern	4 Patterns (760 command/Pattern)
	Auto Pan	2 points to 8 points
	Group	9 Groups (8 presets/Group)
Sensor / Alarm	Sensor	4 Inputs, Photo-Coupler Input
	Alarm	2 Relay Outputs, Max Load : DC 30 V 1 A / AC 125 V 0.3 A
	IP Reset Button	Support
Misc.	Mount Accessory	Mount Adaptor
	Material	Dome Polycarbonate
		Internal Polycarbonate, ABS
		External Aluminum
	Rated Power	PoE+ / AC 24 V (49 W)
	Waterproof	IP66
	Fan	Always ON
Heater	Operation start from Internal Temperature 10°C	
Operation Temperature	-20°C to 50°C	
Weight	about 3.3 Kg	
Dimension	Ø 195.8 mm x 229 mm	

**Part Names and Functions**

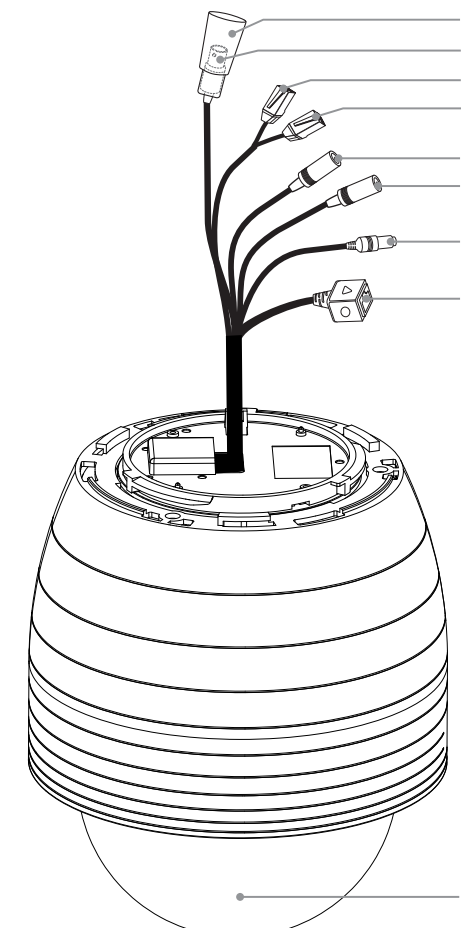

- 1 BNC connector cover cap**
- 2 Video output BNC connector**
- 3 Data Port A (RJ-45)**  
Input data port for alarm (relay) signal. RS-485 data communication is not available.
- 4 Data Port B (RJ-45)**  
Output data port for alarm (relay) signal.
- 5 AUDIO IN (Line Level Input)**  
Input for a mono microphone, or a line-in mono signal.
- 6 AUDIO OUT (Line Level Output)**  
Connect to an active speaker with a built-in amplifier.
- 7 Power input jack**
- 8 ETHERNET Port**  
Connects to a PC or a network via a hub with a 10 BASE-T/100 BASE-TX cable attached RJ-45 connector.
- 9 Dome Cover**

**Accessories**

- Software Installation CD
- Cover adaptor
- Mount adaptor
- RJ-45 Cable
- RJ-45 adaptor cable
- Wrench
- M3 SAMS Screws

## Connection

### Connecting Display device

The video signal connection between the camera and the monitor.

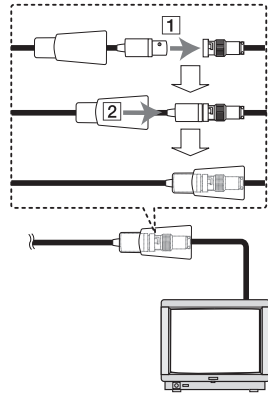

### ALARM input connection

Connect sensor and alarm devices to corresponding terminals accordingly.

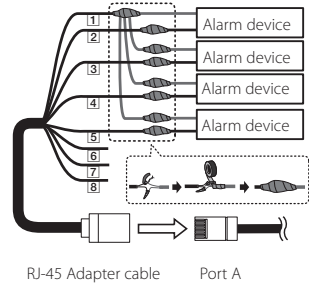

PORT A of the LW9422 series		
Description	Color	
ALARM IN COM	Black	
ALARM IN 1	Brown	
ALARM IN 2	Red	
ALARM IN 3	Orange	
ALARM IN 4	Green	

### ALARM output connections

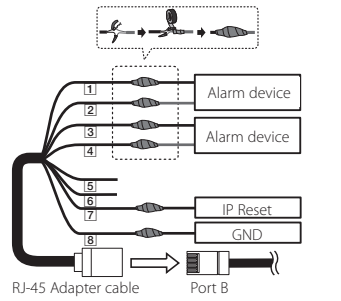

PORT B of the LW9422 series		
Description	Color	
ALARM OUT 1 A	Blue	
ALARM OUT 1 B	Violet	
ALARM OUT 2 A	Gray	
ALARM OUT 2 B	White	
IP RESET	Pink	
GND	Red/White	

### CAUTION:

Output specifications are lowactive, open-collector and a drive capacity of DC 30 V 1 A / AC 125 V 0.3 A. Connecting the alarm out incorrectly may cause damaging the camera.

### Connecting Network

Connect the IP camera to your network using a standard RJ-45 network cable as shown below.

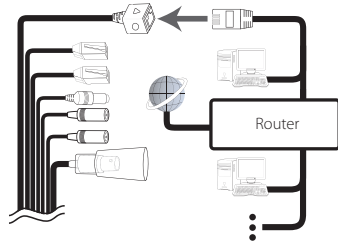

### Connecting power source

Connect a AC 24 V or PoE+ power source to the power input terminal as shown below. (Connect to the AC 24 V UL Listed, Class 2 Power Supply only on the unit.)

### NOTE:

In case of connecting both AC 24 V and PoE+, PoE+ has a priority.

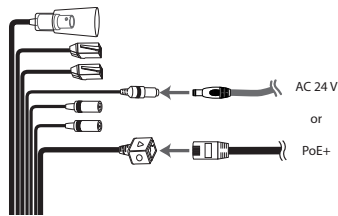

### Connecting Microphone and Speaker Device

Optionally connect an active speaker and/or external microphone with a built-in amplifier.

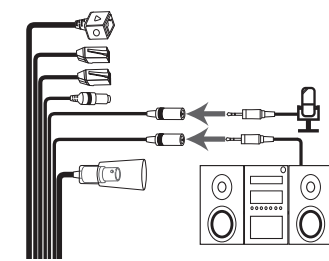

### NOTE:

Keep the microphone away from the speaker to avoid howling.

## Using the SD Card

You can record your surveillance environment with the SD card even if the network is disconnected condition.

### To insert the SD card

1. Remove the dome cover.

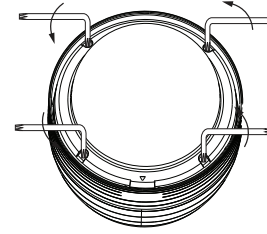

2. Insert the SD card carefully as shown in the following illustrations. Make sure the SD card terminal position before insert the SD card. Push the back end of the SD card to fix it at the last step.

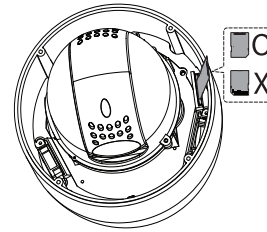

### NOTES:

- Do not use the power too much when you insert the SD card. The SD card may be damaged.
- If you insert the SD card in the wrong position, the SD card may be damaged or it may cause the malfunction of the SD Card Slot.
- Keep the terminal part of the SD card in clean. Be careful the terminal part of the SD card not to dusty.
- As the SD card is consumable, the SD card end its days and may be not able to save data if you use it more than over certain times. In this case, replace SD card to buy a new one.

### Remove the SD card

1. Press the back end of the SD card to release the lock condition.

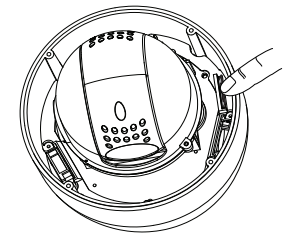

2. Take the SD card out carefully from the camera. It may cause a malfunction of the SD card or the SD card slot if you use the power too much at lock status.

### CAUTION:

- If you install the SD card on the camera and remove with the SD card condition indicator lights on, you must unmount the SD card by using the [SD Card > Configuration > Disk Management > Unmount] menu. The SD card data is compromised or the camera may not operate normally, if you remove the card without use [Unmount] function.
- Do not insert Micro SD card to SD card adapter. It is recommended to use a standard SD card.
- Insert the SD card before install the camera.
- LG Electronics is not responsible for deleted data caused by user mishandling when you insert or remove the SD card.

## Installation

### Wall mount (optional)

Install the camera by the following order.

1. Install the wall mount assembly as shown below.

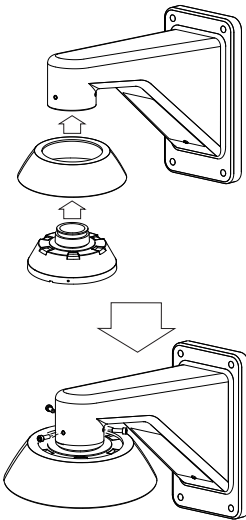

2. Drill a hole on the wall where you want to install the pipe. Pass the connection cable through the wall mount assembly so that they hang down.

3. Connect the safety cable to the camera in order to prevent a camera from falling.

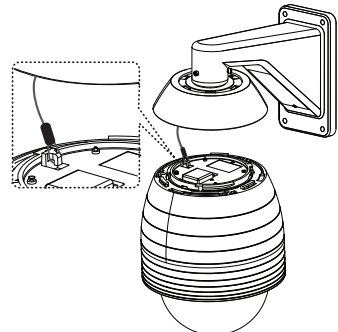

4. Connect the cable to the camera jack.

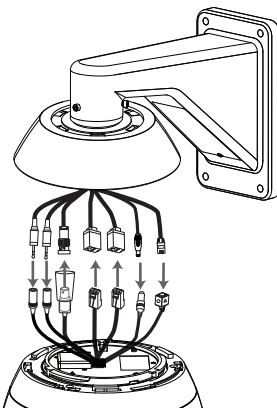

5. Assemble the camera to the mounting adaptor by turning it clockwise. Tighten the M3 SAMS Screws and then align the cover adaptor and main body.

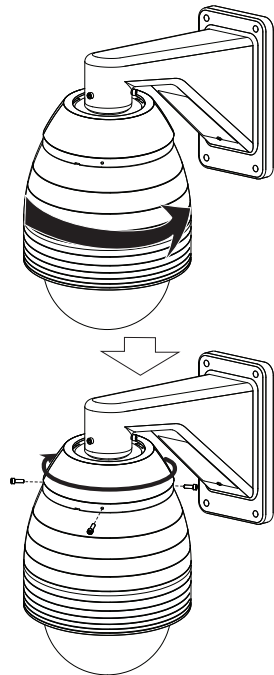

### CAUTION:

Remove the dome cover carefully to prevent falling.

### Pendant mount (optional)

Install the camera by the following order.

1. Install the pendant mount assembly.

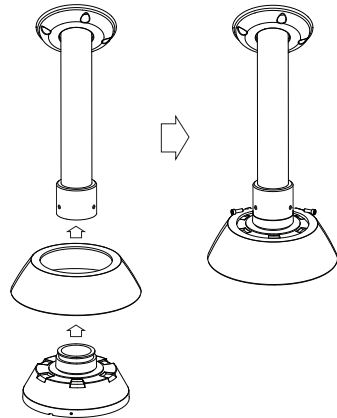

2. Drill a hole on the wall where you want to install the pipe. Pass the connection cable through the pendant mount assembly so that they hang down.

3. Connect the safety cable to the camera.
4. Connect the cables to the camera jack.

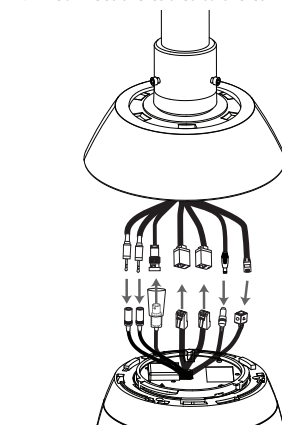

5. Assemble the camera to the mounting adaptor by turning it clockwise. Tighten the M3 SAMS Screws and then align the cover adaptor and main body.

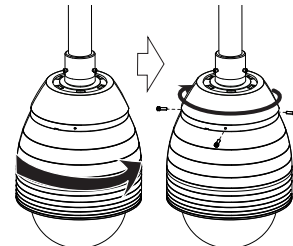

### Parapet mount (optional)

1. Install the parapet mount assembly as shown below.

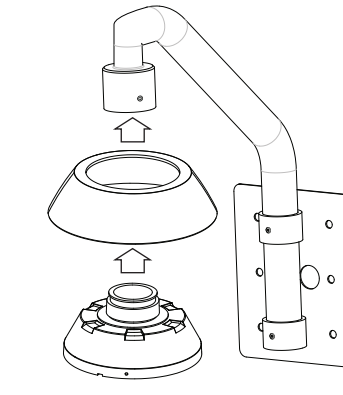

2. Drill a hole on the wall where you want to install the parapet. Pass the connection cable through the parapet mount assembly so that they hang down.

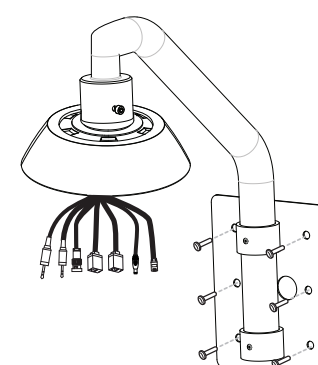

3. Connect the safety cable to the camera.
4. Connect the cables to the camera jack.

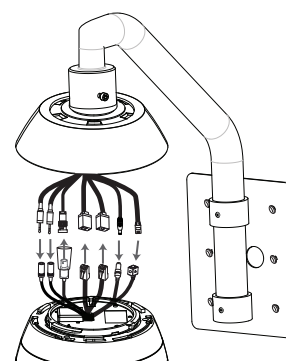

5. Assemble the camera to the mounting adaptor by turning it clockwise. Tighten the M3 SAMS Screws and then align the cover adaptor and main body.

