



OWNER'S MANUAL

IR Dome Camera

Please read this manual carefully before operating your set and retain it for future reference.

MODEL

LCV5300R-BN

LCV5300R-BP



MFL67417416



CAUTION

**RISK OF ELECTRIC SHOCK
DO NOT OPEN**



CAUTION: TO REDUCE THE RISK OF ELECTRIC SHOCK
DO NOT REMOVE COVER (OR BACK)
NO USER-SERVICEABLE PARTS INSIDE
REFER SERVICING TO QUALIFIED SERVICE PERSONNEL.



This lightning flash with arrowhead symbol within an equilateral triangle is intended to alert the user to the presence of uninsulated dangerous voltage within the product's enclosure that may be of sufficient magnitude to constitute a risk of electric shock to persons.



The exclamation point within an equilateral triangle is intended to alert the user to the presence of important operating and maintenance (servicing) instructions in the literature accompanying the product.

FCC WARNING: This equipment may generate or use radio frequency energy. Changes or modifications to this equipment may cause harmful interference unless the modifications are expressly approved in the instruction manual. The user could lose the authority to operate this equipment if an unauthorized change or modification is made.

REGULATORY INFORMATION: FCC Part 15

This equipment has been tested and found to comply with the limits for a Class A digital device, pursuant to Part 15 of the FCC Rules. These limits are designed to provide reasonable protection against harmful interference when the equipment is operated in a commercial environment. This equipment generates, uses, and can radiate radio frequency energy and, if not installed and used in accordance with the instruction manual, may cause harmful interference to radio communications. Operation of this equipment in a residential area is likely to cause harmful interference in which case the user will be required to correct the interference at his own expense.

- A suitable conduit entries, knock-outs or glands shall be provided in the cable entries of this product in the end user.

- **Caution:** Danger of explosion if battery is incorrectly replaced. Replaced only with the same or equivalent type recommended by the manufacturer. Dispose of used batteries according to the manufacturer's instructions.
- Holes in metal, through which insulated wires pass, shall have smooth well rounded surfaces or shall be provided with brushings.

This Class A digital apparatus complies with Canadian ICES-003.
Cet appareil numérique de la classe A est conforme à la norme NMB-003 du Canada.

Warning: Do not install this equipment in a confined space such as a bookcase or similar unit.

Warning: Wiring methods shall be in accordance with the National Electric Code, ANSI/NFPA 70.

Warning: This is a class A product. In a domestic environment this product may cause radio interference in which case the user may be required to take adequate measures.

Warning: To reduce a risk of fire or electric shock, do not expose this product to rain or moisture.

Caution: This installation should be made by a qualified service person and should conform to all local codes.

Caution: To avoid electrical shock, do not open the cabinet. Refer servicing to qualified personnel only.

Caution: The apparatus shall not be exposed to water (dripping or splashing) and no objects filled with liquids, such as vases, shall be placed on the apparatus.

Note:

Please make sure the product is installed appropriate places where secured from flood, such as under the eaves, to operate properly. This product is certified as IP66 standard. However, if there is any flood concerns, it is highly recommended to use an outdoor Housing. When you install the camera inside an outdoor Housing, please use one of the following methods:

1. Remove the front glass of Housing before installing the camera.
2. To keep the front glass of Housing, remove the front cover, and then put the camera close to the front glass.

To disconnect power from mains, pull out the mains cord plug. When installing the product, ensure that the plug is easily accessible.

Disposal of your old appliance



1. When this crossed-out wheeled bin symbol is attached to a product it means the product is covered by the European Directive 2002/96/EC.
2. All electrical and electronic products should be disposed of separately from the municipal waste stream via designated collection facilities appointed by the government or the local authorities.
3. The correct disposal of your old appliance will help prevent potential negative consequences for the environment and human health.
4. For more detailed information about disposal of your old appliance, please contact your city office, waste disposal service or the shop where you purchased the product.

EEE Compliance with Directive. (for Turkey only)



LG Electronics hereby declares that this/ these product(s) is/are in compliance with the essential requirements and other relevant provisions of Directive 2004/108/EC, 2006/95/EC, and 2009/125/EC.

European Standards Centre:

Krijgsman 1, 1186 DM Amstelveen The Netherlands

Important Safety Instructions

1. Read these instructions.
2. Keep these instructions.
3. Heed all warnings.
4. Follow all instructions.
5. Do not use this apparatus near water.
6. Clean only with dry cloth.
7. Do not block any ventilation openings. Install in accordance with the manufacturer's instructions.
8. Do not install near any heat sources such as radiators, heat registers, stoves, or other apparatus (including amplifiers) that produce heat.
9. Do not defeat the safety purpose of the polarized or grounding-type plug. A polarized plug has two blades with one wider than the other. A grounding type plug has two blades and a third grounding prong. The wide blade or the third prong are provided for your safety. If the provided plug does not fit into your outlet, consult an electrician for replacement of the obsolete outlet.
10. Protect the power cord from being walked on or pinched particularly at plugs, convenience receptacles, and the point where they exit from the apparatus.
11. Only use attachments/accessories specified by the manufacturer.
12. Use only with the cart, stand, tripod, bracket, or table specified by the manufacturer, or sold with the apparatus. When a cart is used, use caution when moving the cart/apparatus combination to avoid injury from tip-over.
13. Unplug this apparatus during lightning storms or when unused for long periods of time.
14. Refer all servicing to qualified service personnel. Servicing is required when the apparatus has been damaged in any way, such as power-supply cord or plug is damaged, liquid has been spilled or objects have fallen into the apparatus, the apparatus has been exposed to rain or moisture, does not operate normally, or has been dropped.



Cautions for Safe Operation

Power Supply

This camera must always be operated a DC 12 V or AC 24 V Certified/Listed, class 2 power supply only.

Handling of the unit

Be careful not to spill water or other liquids on the unit. Be cautious not to get combustible or metallic material inside the body. If used with foreign matter inside, the camera is liable to fail or to get cause of fire or electric shock.

- Remove dust or dirt on the surface of the lens with a blower.
- Use a dry soft cloth to clean the body. If it is very dirty, use a cloth dampened with a small quantity of neutral detergent then wipe dry.
- Avoid the use of volatile solvents such as thinners, alcohol, benzene and insecticides. They may damage the surface finish and/or impair the operation of the camera.

Operating and storage location

Avoid viewing a very bright object (such as light fittings) during an extended period. Avoid operating or storing the unit in the following locations.

- Extremely hot or cold places (operating temperature -10 °C to 50 °C, however, we recommend that the unit be used within a temperature range of 0 °C to 45 °C)
- Damp or dust place
- Places exposed to rain
- Places subject to strong vibration
- Close to generators of powerful electromagnetic radiation such as radio or TV transmitters.

Contents

Features	8	Privacy Mask Setting	29
Accessories.....	8	Special Menu Settings	31
Part Names and Functions	9	SYSTEM Setting	35
Part Names and Functions	10	Specification	36
Connections	11		
Basic connection.....	11		
Installation	12		
Mounting the Camera.....	12		
Image Adjustment	15		
Menu Operation	18		
OSD Menu Overview	19		
General Operation.....	21		
Exposure Settings.....	22		
White Balance settings	25		
Day/Night Setting	26		
SmartIR Setting	27		
Motion Detection Setting.....	28		
3D-DNR Setting.....	29		

Features



This IR Bullet Camera is designed for installation in a video surveillance system.

This manual contains instructions on how to install and manage the IR Bullet Camera in your video surveillance system.

Should you require any technical assistance, please contact authorized service center.

- High resolution and high sensitivity with a 6 mm (1/3 Type) CCD.
- Day & Night function.
- HSBLC/BLC covers various light conditions.
- Weather Proof: IP66

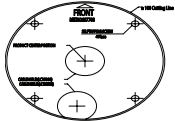
Accessories

Installation sticker	
Wrench	
M4 Fixing screws	

Part Names and Functions

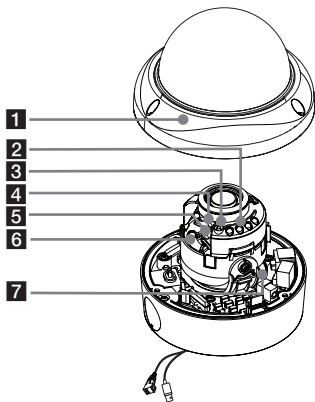

1 Dome Cover

2 IR LED

3 IR Sensor

4 Focus lock lever

Fixes the focus position after adjusting.

5 Zoom lock lever

Fixes the zoom position after adjusting.

6 Rotate adjuster

7 Pan adjuster

Part Names and Functions

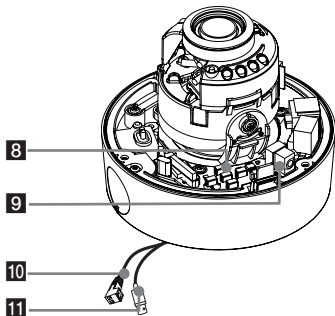

8 Setup menu control buttons

9 Video Out connector

Use this jack for checking the picture with portable monitor when install the camera.

10 Power input connector

Supplies AC 24 V or DC 12 V from an external power source.

11 Video output connector (BNC type)

Connections

Basic connection

The peripheral devices (DVR, monitor, etc.), AC/DC adapter and cables are not supplied.

1. Make the video signal connection between the camera and the monitor or DVR.

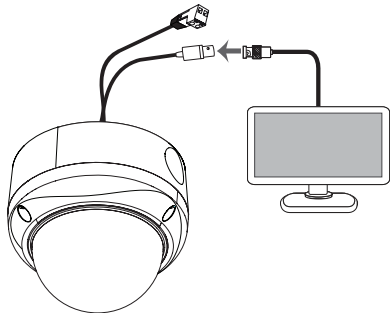

2. Connect an external power source to the power input jack of the camera.

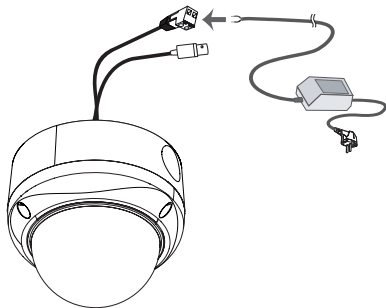

Installation

Mounting the Camera

Note:

Refer the manual of Dome bracket adaptor when you mount the camera on the wall, pendant and parapet.

Surface mount

Follow the instructions below to surface mount the camera with supplied camera mounting bracket.

1. Use the installation guide template to check the mounting location. Face the front of the label toward the area of interest. Using the template as a guide, make a hole through the ceiling.



2. Pass the connection cable through the inner side of the ceiling.

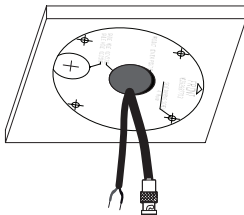

Installation

3. Install the camera mounting bracket to the ceiling.

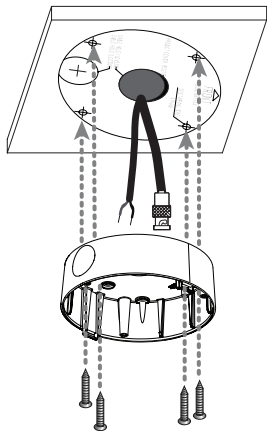

4. Connect the cables to the cable jacks of the camera body.

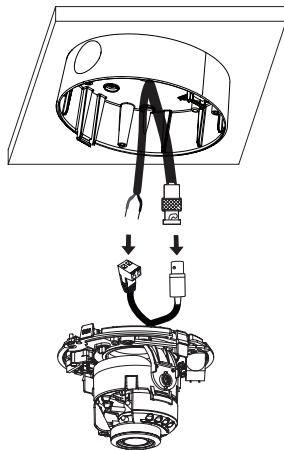

Installation

5. Assemble the camera and the housing. Make sure when you assemble the camera in the right direction. And then, assemble the dome cover and lens cover.

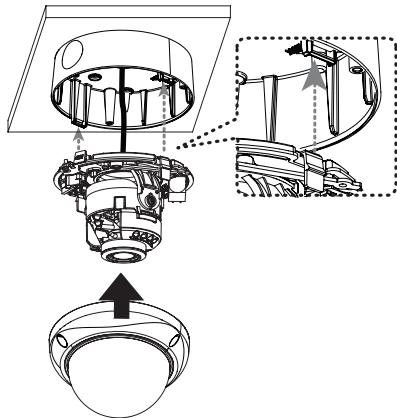

6. Use the supplied wrench to tighten the screws

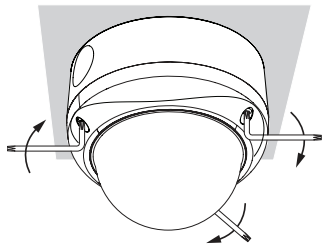

Installation

Image Adjustment

You can manually adjust the pan/tilt/azimuth angles, focus, and zoom while observing the connected monitor.

Notes:

- Do not hold the camera by lens unit to adjust panning, tilting, or azimuth.
 - The video output to the BNC will be interrupted while a portable monitor is connected to the video jack.
1. Use the supplied wrench to loosen the screws and remove the dome cover. Remove the Dome cover and lens cover.

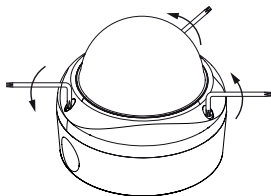

2. Connect a portable monitor to the video jack.

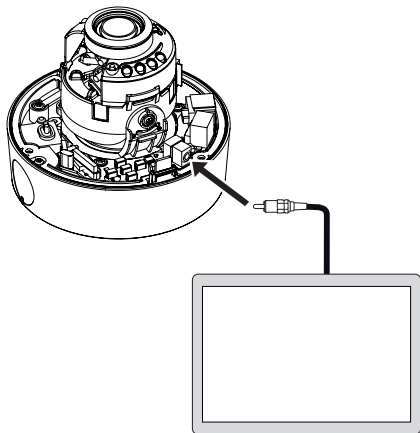

Installation

3. Adjust the pan/tilt/rotate position of the camera.

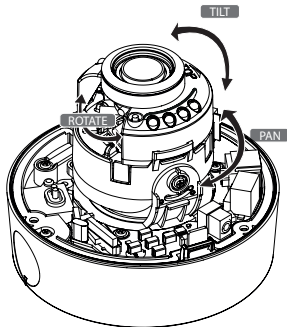

4. Adjust the zoom.

4-1. Unlock the zoom lever.

4-2. Move the lever to adjust the zoom.

4-3. Lock the lever.

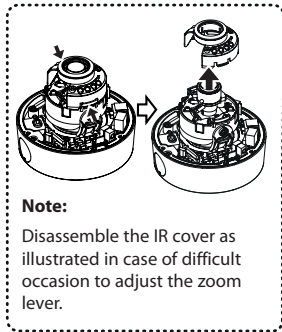
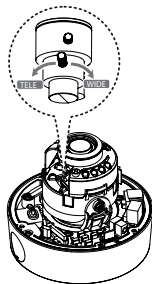

Note:

Disassemble the IR cover as illustrated in case of difficult occasion to adjust the zoom lever.

Installation

5. Adjust the focus.
 - 5-1. Unlock the focus lever.
 - 5-2. Move the lever to adjust the focus.
 - 5-3. Lock the lever.

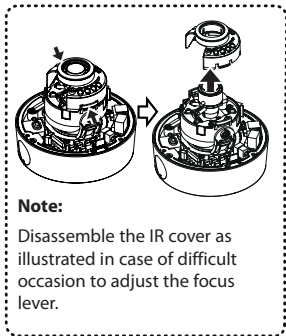
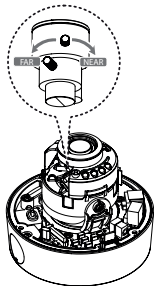

6. This camera utilizes an on-screen user MENU. To set items on the menu, use the following buttons. After then attach the lens cover and dome cover.

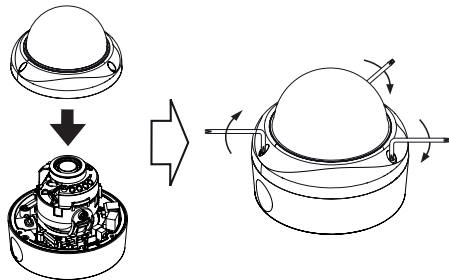

Menu Operation

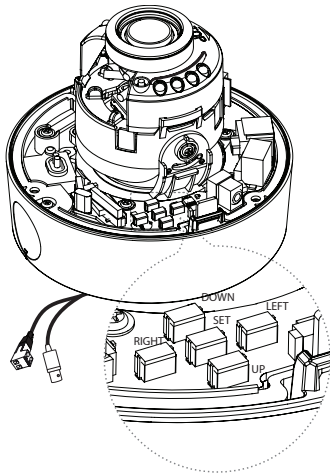

- **UP button:**
Used to move upper direction on the menu screen. Use this button to select an item or adjust the parameters.
- **DOWN button:**
Used to move lower direction on the menu screen. Use this button to select an item or adjust the parameters.
- **RIGHT button:**
Moves the cursor to the right. Used to increment the value selected in the menu. The parameter changes each time this button is pressed.
- **LEFT button:**
Moves the cursor to the left. Used to decrement the value selected in the menu. The parameter changes each time this button is pressed.
- **SET button:**
Executes selections and displays a submenu for an item with the  mark.

Menu Operation

OSD Menu Overview

The following table shows the list of menu items and options. You can adapt the camera to your requirements by setting up the respective items in these menus.

Main Menu	Sub Menu	Contents	
EXPOSURE	ALC /ELC	BACKLIGHT	OFF/BLC/HSBLC
		BRIGHTNESS	0 to 100
		AGC	OFF/LOW/MIDDLE/HIGH
		SHUTTER	x512, ..., x2, AUTO, OFF, A.FLK, 1/160, ..., 1/120 000
		SENS-UP	OFF / AUTO
		EXIT	RET/ TOP / END
WHITE BAL	ATW	-	
	AUTO	-	
	AWC → SET KET	-	
	MANUAL	RED	-100 to 100
		BLUE	-100 to 100
	EXIT	RET/ TOP / END	

DAY/ NIGHT	AUTO	BURST	ON/OFF	
		LEVEL	LOW/ MIDDLE/ HIGH/USER	
		DWELL TIME	3 SEC to 60 SEC	
	DAY	-		
	NIGHT	BURST	ON/OFF	
EXIT	RET/ TOP / END			
SMART IR	POSITION ↔	1 to 7		
	POSITION ↑↓	1 to 7		
	SIZE ↔	2 to 8		
	SIZE ↑↓	2 to 8		
	EXIT	RET/ TOP / END		
MOTION DET	OFF	-		
	ON	AREA SETUP	AREA SELECTION	1 to 8
			STATE	ON / OFF
			POSITION ↔	0 to 7
			POSITION ↑↓	0 to 5
			SIZE ↔	1 to 8
	SIZE ↑↓	1 to 6		
	SENSITIVITY	0 to 100		
	DISPLAY	OFF / OUTLINE / MASK1 / MASK2		
	ALARM OUT	OFF / MESSAGE		

Menu Operation

MOTION DET	ON	EXIT	RET/TOP / END	
3D-DNR	0 to 100	-		
PRIVACY MASK	OFF	-		
	ON	RECTANGLE	MASK SELECTION	1 to 8
			DISPLAY	OFF / MOSAIC / COLOR1 to COLOR8
			POSITION ←→	2 to 98
			POSITION ↑↓	2 to 98
			SIZE ←→	4 to 100
			SIZE ↑↓	4 to 100
			CIRCLE	MASK SELECTION
		DISPLAY		OFF / MOSAIC / COLOR1 to COLOR8
		POSITION ←→		0 to 100
		POSITION ↑↓		0 to 100
		SIZE ←→		1 to 15
		SIZE ↑↓		1 to 15
		RADIUS		1 to 100

PRIVACY MASK	ON	POLYGON	MASK SELECTION	1 to 2
			DISPLAY	OFF / MOSAIC / COLOR1 to COLOR8
			SHAPE	-
			POSITION	-
EXIT		RET/TOP / END		
SPECIAL	D-ZOOM	OFF	-	
		ON	ZOOM	x 1.0 to x 16.0
			PAN	-100 to 100
			TILT	-100 to 100
	D-EFFECT	OFF / MIRROR / V-FLIP / ROTATE		
	SHARPNESS	0 to 100		
	COLOR	0 to 100		
	SYNC	INT / LL		
	USER TITLE	ON / OFF		
	LANGUAGE	ENG/CHN/KOR/JAP/FRE/ITA/SPA/POR/DUT/GER/POL/RUS/TUR/ARA/HEB		
	EXIT	RET/ TOP / END		

Menu Operation

SYSTEM	FACTORY RESET	-
	EXIT	RET/TOP / END
EXIT	RET/TOP / END	

General Operation

1. Press [SET] button.
The Main OSD menu screen appears on the monitor.

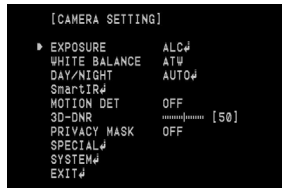

2. Use [UP] or [DOWN] button to select an option then press [SET] button.
Submenu appears on the monitor.
3. Use [UP] or [DOWN] button to select a submenu option.
4. Use [LEFT] or [RIGHT] button to select a value.
5. Select [EXIT] option then press [SET] to exit the setup menu. In the submenu, use [UP] or [DOWN] button to select the [RETURN] then press [SET] to return to the

Menu Operation

previous setup menu.

- RETURN: Return to the previous.

Exposure Settings

You can set the exposure options using the EXPOSURE menu.

1. Select [EXPOSURE] option on the [CAMERA SETTING] menu.
2. Use [LEFT] or [RIGHT] button to select a mode.
3. Press [SET] button and the EXPOSURE menu appears.

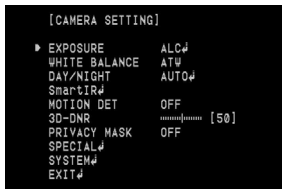

Backlight setting

Use Backlight option to view the object clearly in backlight conditions.



1. Select [Backlight] option.
2. Use [LEFT] or [RIGHT] button to select a mode then press [SET].
 - BLC: Camera's backlight compensation feature helps alleviate issues of visibility in high contrast areas. Set the BLC limit.

Note:

If the [DAY/NIGHT] option is set to [NIGHT] mode, the BLC mode of the [EXPOSURE] function is not available and [---] mark is displayed.

Menu Operation

- HSBLC: Use for masking brightness of the specific area to view the subject more clearly. The HSBLC mode is automatically activated only in low luminance scene.
 - > AREA SETTING: Use [LEFT] or [RIGHT] button to select a area then use [UP] or [DOWN] button to select a [ON] or [OFF]. Press [SET] to exit the Area setting menu.
 - > GRAY SCALE: Use [LEFT] or [RIGHT] button to select a gray scale. (GRAY, D.GRAY, BLACK)
 - > USER SCALE: Use [LEFT] or [RIGHT] button to select a bright level. (5 level)
 - > MASK: Use [LEFT] or [RIGHT] button to select [ON] or [OFF].
If you set the MASK to ON, the mask function is activate only when the HSBLC is automatically activated in low luminance scene.
- OFF: Not used.

BRIGHTNESS setting

You can increase the brightness of the darkened video. If you set the brightness to lower value, the image is darkened. If you set the brightness to higher value, the image gets bright.



1. Select [BRIGHTNESS] option.
2. Use [LEFT] or [RIGHT] button to set the bright level.

Menu Operation

AGC (Automatic Gain Control) setting

If the images are too dark, change the maximum [AGC] value to make the images brighter. But noise is increase.



1. Select [AGC] option.
2. Use [LEFT] or [RIGHT] button to select a mode.

SHUTTER (Shutter Speed) setting

Select the desired shutter speed for camera exposure. You can change the shutter speed to higher speed to capture fast-moving subjects, though the image becomes darker.



1. Select [SHUTTER] option.
2. Use [LEFT] or [RIGHT] button to set shutter speed.

Notes:

- When the SHUTTER is set to AUTO, the picture may become unstable if the camera faces a bright fluorescent light directly. Therefore, take care when installing.
- Set the Shutter OFF when Color Rolling occurs in the indoor scene. Recommend the Shutter Auto in the outdoor scene.

Menu Operation

SENS-UP setting

If pictures are not clear due to darkness, this SENS-UP operation would increase the sensitivity of picture.



1. Use [UP] or [DOWN] button to select [SENS-UP] option.
2. Use [LEFT] or [RIGHT] button to select mode.
 - AUTO: Adjust the sensitivity of the picture automatically.
 - > SENS-UP LIMIT: Use [LEFT] or [RIGHT] button to set the SENS-UP limit.
 - OFF: Not used.

Note:

If you set to one of the SHUTTER options except AUTO and OFF on the [SHUTTER] menu, the [SENS-UP] setting is not available and [---] mark is displayed.

White Balance settings

Select the method by which the camera shifts its output colors to compensate for the color of a light source.

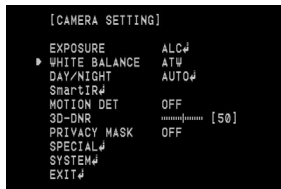

1. Select [WHITE BAL] option.
2. Use [LEFT] or [RIGHT] button to select a mode then press [SET].
 - ATW (Auto-Tracing White Balance): Use [LEFT] or [RIGHT] button to select the ATW then press [SET]

Menu Operation

button.

- MANUAL: You can set the white balance options manually.
 - > RED: Obtains the optimum amount of red gain.
 - > BLUE: Obtains the optimum amount of blue gain.
- AWC→SET KEY: If you select the AWC→SET KEY mode, you will be able to set up the White Balance automatically using [SET] button.
- AUTO : Use [LEFT] or [RIGHT] button to select the AUTO then press [SET] button.

Day/Night Setting

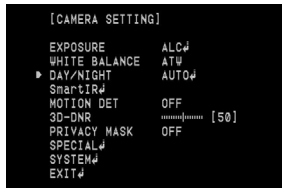

1. Select [DAY/NIGHT] option.
2. Use [LEFT] or [RIGHT] button to select mode for Day/Night function.
 - AUTO: You will be able to change the Day/Night mode automatically.

Note:

If you set the AGC to [OFF] on the [EXPOSURE] menu, the AUTO mode of the DAY/NIGHT function is not available and [---] mark is displayed.

- > BURST: Use [LEFT] or [RIGHT] button to select [ON] or [OFF].

Menu Operation

- > LEVEL: Use [LEFT] or [RIGHT] button to select a level.
- > DWELL TIME: Use [LEFT] or [RIGHT] button to select a dwell time.
- DAY: Color mode enabled.
- NIGHT: Black-and-white mode enabled.
- > BURST: Use [LEFT] or [RIGHT] button to select [ON] or [OFF].

SmartIR Setting

SmartIR function improve the sensitivity in the low luminance. SmartIR analyze the image of the screen, when the subject is close. Then SmartIR reduce the IR LED brightness and gain to prevent saturation of the closed subject.



1. Select [SmartIR] option.
2. Use [UP] or [DOWN] to select an option then use [LEFT] or [RIGHT] button to adjust the option.
 - POSITION \leftrightarrow : Moves horizontal position of the prevent saturation zone.
 - POSITION \updownarrow : Moves vertical position of the prevent saturation zone.

Menu Operation

- SIZE \leftrightarrow : Enlarge or decrease the horizontal size of the prevent saturation zone.
- SIZE \updownarrow : Enlarge or decrease the vertical size of the prevent saturation zone.

Motion Detection Setting

The motion detection detects the moving objects in the scene by monitoring changes in brightness level. You can select the level of sensitivity for motion detection to 8 zone.

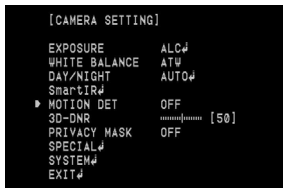

1. Select [MOTION DET] option.
2. Use [LEFT] or [RIGHT] button to select a [ON] and press [SET]. The MOTION DETECTION menu appears.

3. Select [AREA SETUP] option.
 - Use [LEFT] or [RIGHT] button to select a area (1/8 to 8/8) on the [AREA SELECTION].
 - Use [LEFT] or [RIGHT] button to set up the ON or OFF on the STATE.
 - Use [UP] or [DOWN] to select an option then use [LEFT] or [RIGHT] button to adjust the option.
 - > POSITION \leftrightarrow : Moves horizontal position of the mask.
 - > POSITION \updownarrow : Moves vertical position of the mask.
 - > SIZE \leftrightarrow : Enlarge or decrease the horizontal size of the mask.
 - > SIZE \updownarrow : Enlarge or decrease the vertical size of the mask.
4. Use [SENSITIVITY] option to obtain the optimum detection level.
5. Use [LEFT] or [RIGHT] button to select the DISPLAY option.
6. Use [LEFT] or [RIGHT] button to select the ALARM OUT option.

Menu Operation

3D-DNR Setting

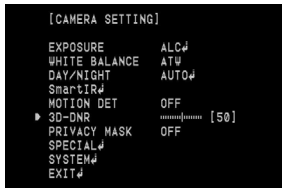

1. Select [3D-DNR] option.
If pictures are not clear due to brightness, this option would reduce the noise of picture.
2. Use [LEFT] or [RIGHT] button to select a value.

Privacy Mask Setting

This function is aiming at the protection of personal privacy, selecting a screen part black not to be displayed in the screen. Up to 8 zones can be registered.

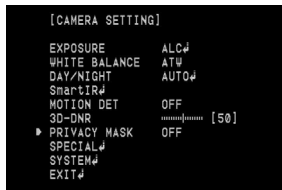

1. Select [PRIVACY] option.
2. Use [LEFT] or [RIGHT] button to select a [ON] and press [SET]. The PRIVACY SETUP menu appears.
 - RECTANGLE :
 - > Use [LEFT] or [RIGHT] button to select a mask (MASK1 to MASK8) on the [MASK SELECTION].
 - > Use [LEFT] or [RIGHT] button to set up the

Menu Operation

OFF, MOSAIC, COLOR 1 to COLOR 8 on the DISPLAY option.

- > Use [UP] or [DOWN] to select an option then use [LEFT] or [RIGHT] button to adjust the option.

- POSITION \leftrightarrow : Moves horizontal position of the mask.
- POSITION \updownarrow : Moves vertical position of the mask.
- SIZE \leftrightarrow : Enlarge or decrease the horizontal size of the mask.
- SIZE \updownarrow : Enlarge or decrease the vertical size of the mask.

- CIRCLE :

- > Use [LEFT] or [RIGHT] button to select a mask (MASK1 to MASK4) on the [MASK SELECTION].
- > Use [LEFT] or [RIGHT] button to set up the OFF, MOSAIC, COLOR 1 to COLOR 8 on the DISPLAY option.
- > Use [UP] or [DOWN] to select an option then use [LEFT] or [RIGHT] button to adjust the

option.

- POSITION \leftrightarrow : Moves horizontal position of the mask.
- POSITION \updownarrow : Moves vertical position of the mask.
- SIZE \leftrightarrow : Enlarge or decrease the horizontal size of the mask.
- SIZE \updownarrow : Enlarge or decrease the vertical size of the mask.
- RADIUS SIZE : You can adjust the RADIUS SIZE (1 to 100).

- POLYGON :

- > Use [LEFT] or [RIGHT] button to select a mask (MASK1 to MASK2) on the [MASK SELECTION].
- > Use [LEFT] or [RIGHT] button to set up the OFF, MOSAIC, COLOR 1 to COLOR 8 on the DISPLAY option.
- > Use the [LEFT], [RIGHT], [UP], [DOWN], [SET] button to draw the polygon on the [SHAPE].
- > Use the [LEFT], [RIGHT], [UP], [DOWN],

Menu Operation

[SET] button to move the polygon on the [POSITION].

Note:

You can adjust the mask color manually except for color 8.

Special Menu Settings

This menu lets you adjust and set up D-ZOOM, D-EFFECT, SHARPNESS, COLOR, SYNC, USER TITLE, LANGUAGE function by yourself in the SPECIAL menu.

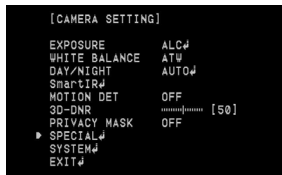

1. Select [SPECIAL] option.
2. Press [SET] button and the SPECIAL menu appears.

Menu Operation

D-ZOOM (Digital Zoom) Setting

You can select the digital zoom level.



1. Select [D-ZOOM] option on the [SPECIAL] menu.
2. Use [LEFT] or [RIGHT] button to select a [ON] then press [SET] the DIGITAL ZOOM menu appears. When you set to ON, the displayed image can be shaking.
3. Use [UP] or [DOWN] to select a option then use [LEFT] or [RIGHT] button to select a level.
 - ZOOM: Use [LEFT] or [RIGHT] button to enlarge the screen.
 - PAN: Use [LEFT] or [RIGHT] button to move the screen.

- TILT: Use [LEFT] or [RIGHT] button to move the screen.

Note:

If you set the [D-ZOOM] to ON, the ZOOM level is set to [x1.0] automatically.

D-EFFECT (Digital effect) Setting

You can select the digital effect.



1. Select [D-EFFECT] option on the [SPECIAL] menu.
2. Use [LEFT] or [RIGHT] button to select a digital effect.
 - V-FLIP: Flip the picture vertically.
 - ROTATE: Rotate the picture. (180°)

Menu Operation

- MIRROR: Turn on the mirror effect.
- OFF: Turn off the digital effect.

SHARPNESS Setting

The degree to which the boundary of the two portions is clearly distinguished.



1. Select [SHARPNESS] option on the [SPECIAL] menu.
2. Use [LEFT] or [RIGHT] button to change and adjust the option. If you set the sharpness value to higher, the image outline becomes sharp. If you set to lower value, the image outline becomes dim.

COLOR Setting

You can switch the displayed picture to gray scale or color.



1. Select [COLOR] option on the [SPECIAL] menu.
2. Use [LEFT] or [RIGHT] button to change and adjust the option.

Menu Operation

SYNC Setting



1. Select [SYNC] option on the [SPECIAL] menu.
2. The [SYNC] option is set to [INT] automatically.

Note:

AC24V Adaptor have to use for [LL] mode setting.

USER TITLE Setting

You can use the camera identification to assign a number and character to the camera. To disappear the user title, select [OFF].

1. Select [USER TITLE] option on the [SPECIAL] menu.
2. Use [LEFT] or [RIGHT] button to select a [ON] then press [SET]. The USER TITLE menu appears.



3. Use [UP], [DOWN], [LEFT] or [RIGHT] button to select a character or number then press [SET] button.
 - CLR: Clear all entered characters and numbers.
 - POS: Move the USER TITLE position on the screen using the arrow buttons.
 - END: Confirm your selection or exit the setting

Menu Operation

- **1** (Blank): Inserts a space at the cursor position.
- **←/→**: Moves cursor to left or right.

LANGUAGE Setting

Select the viewer language for the camera setup menu and OSD information display.



1. Select [LANGUAGE] option on the [SPECIAL] screen.
2. Press [LEFT] or [RIGHT] button to select a language.

SYSTEM Setting

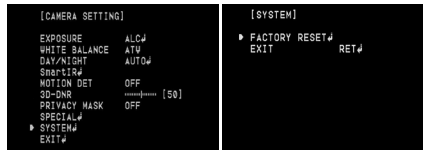

1. Select the [SYSTEM] menu.
2. Press [SET] button and the SYSTEM menu appears.
3. Use [UP] or [DOWN] button to select the option.
 - **FACTORY RESET:** To reset the camera setting to factory setting, select the [FACTORY RESET] option.
4. Press [SET] button to confirm your selection.

Note:

The menu screen is move to top menu, after set up [Factory Reset].

Specification

Item		LCV5300R-BN	LCV5300R-BP
Signal System		NTSC	PAL
Image Device		6 mm (1/3 Type) Exview HAD CCD II	
Total/Effective Pixels Number		520 000 Pixels / 480 000 Pixels	610 000 Pixels / 570 000 Pixels
Horizontal Resolution		650 TV Lines (Color), 700 TV Lines (B/W)	
ISP		XDI-V	
Lens		2.8 mm to 11 mm Vari-focal Lens, F1.2	
Minimum Illumination (30 IRE)	Color	0.03 lx (Sens-up Off, F1.2), 0.000 3 lx (Sens-up Auto, F1.2), 0.000 1 lx (Sens-up x512, F1.2)	
	B/W	0 lx (IR LED ON)	
Day & Night		ICR (AUTO / DAY / NIGHT)	
IRIS Control		DC	
Sync. System		Internal / Line Lock	
Scanning Frequency (H/V)		15.734 KHz / 59.94 Hz	15.625 KHz / 50 Hz
S/N Ratio		50 dB	
Video Output Signal		1 Vp-p Composite (75 Ω)	
IR LED		8 EA	
IR Distance		20 m	

Specification

Item	LCV5300R-BN	LCV5300R-BP
SmartIR	IR Anti-Saturation	
BACKLIGHT	BLC / HSBLC / OFF	
DNR	2D + 3D-DNR	
Exposure	ALC /ELC	
Auto Gain Control	OFF/ LOW/ MIDDLE/ HIGH	
Electronic Shutter Speed	1/60 to 1/120 000	1/50 to 1/120 000
Digital Zoom	x16	
Sens-up	OFF / AUTO(x2, ... x512)	
White Balance	AUTO / ATW / ONE PUSH / MANUAL	
Privacy Zone Masking	14 Masks	
Motion Detection	8 Zones	
Digital Effect	OFF / V-FILP / MIRROR / ROTATE	
Communication	Coaxial Communication	
Power Source	DC 12 V / AC 24 V	
Power Consumption	3.5 W	
Input Current	290 mA	

Specification

Item	LCV5300R-BN	LCV5300R-BP
Operation Temperature/ Humidity	-10 °C to 50 °C / 0 % RH to 80 % RH	
Storage Temperature/ Humidity	-20 °C to 60 °C / 0 % RH to 85 % RH	
Protection	IP66	
Dimension (Ø x H)	140 mm x 122 mm	
Weight	705 g	

