



OWNER'S MANUAL

IR Bullet Camera

Please read this manual carefully before operating your set and retain it for future reference.

MODEL

LCU5500R-BN

LCU5500R-BP



MFL67417442



CAUTION: TO REDUCE THE RISK OF ELECTRIC SHOCK
DO NOT REMOVE COVER (OR BACK)
NO USER-SERVICEABLE PARTS INSIDE
REFER SERVICING TO QUALIFIED SERVICE PERSONNEL.



This lightning flash with arrowhead symbol within an equilateral triangle is intended to alert the user to the presence of uninsulated dangerous voltage within the product's enclosure that may be of sufficient magnitude to constitute a risk of electric shock to persons.



The exclamation point within an equilateral triangle is intended to alert the user to the presence of important operating and maintenance (servicing) instructions in the literature accompanying the product.

FCC WARNING: This equipment may generate or use radio frequency energy. Changes or modifications to this equipment may cause harmful interference unless the modifications are expressly approved in the instruction manual. The user could lose the authority to operate this equipment if an unauthorized change or modification is made.

REGULATORY INFORMATION: FCC Part 15

This equipment has been tested and found to comply with the limits for a Class A digital device, pursuant to Part 15 of the FCC Rules. These limits are designed to provide reasonable protection against harmful interference when the equipment is operated in a commercial environment. This equipment generates, uses, and can radiate radio frequency energy and, if not installed and used in accordance with the instruction manual, may cause harmful interference to radio communications. Operation of this equipment in a residential area is likely to cause harmful interference in which case the user will be required to correct the interference at his own expense.

- A suitable conduit entries, knock-outs or glands shall be provided in the cable entries of this product in the end user.

- **Caution:** Danger of explosion if battery is incorrectly replaced. Replaced only with the same or equivalent type recommended by the manufacturer. Dispose of used batteries according to the manufacturer's instructions.
- Holes in metal, through which insulated wires pass, shall have smooth well rounded surfaces or shall be provided with brushings.

This Class A digital apparatus complies with Canadian ICES-003.
Cet appareil numérique de la classe A est conforme à la norme NMB-003 du Canada.

Warning: Do not install this equipment in a confined space such as a bookcase or similar unit.

Warning: Wiring methods shall be in accordance with the National Electric Code, ANSI/NFPA 70.

Warning: This is a class A product. In a domestic environment this product may cause radio interference in which case the user may be required to take adequate measures.

Warning: To reduce a risk of fire or electric shock, do not expose this product to rain or moisture.

Caution: This installation should be made by a qualified service person and should conform to all local codes.

Caution: To avoid electrical shock, do not open the cabinet. Refer servicing to qualified personnel only.

Caution: The apparatus shall not be exposed to water (dripping or splashing) and no objects filled with liquids, such as vases, shall be placed on the apparatus.

Note:

Please make sure the product is installed appropriate places where secured from flood, such as under the eaves, to operate properly. This product is certified as IP66 standard. However, if there is any flood concerns, it is highly recommended to use an outdoor Housing. When you install the camera inside an outdoor Housing, please use one of the following methods:

1. Remove the front glass of Housing before installing the camera.
2. To keep the front glass of Housing, remove the front cover, and then put the camera close to the front glass.

To disconnect power from mains, pull out the mains cord plug. When installing the product, ensure that the plug is easily accessible.

Disposal of your old appliance



1. When this crossed-out wheeled bin symbol is attached to a product it means the product is covered by the European Directive 2002/96/EC.
2. All electrical and electronic products should be disposed of separately from the municipal waste stream via designated collection facilities appointed by the government or the local authorities.
3. The correct disposal of your old appliance will help prevent potential negative consequences for the environment and human health.
4. For more detailed information about disposal of your old appliance, please contact your city office, waste disposal service or the shop where you purchased the product.

EEE Compliance with Directive. (for Turkey only)



LG Electronics hereby declares that this/ these product(s) is/are in compliance with the essential requirements and other relevant provisions of Directive 2004/108/EC and 2011/65/EU.

Contact office for compliance of this product:

LG Electronics Inc.
EU Representative, Krijgsman 1, 1186 DM
Amstelveen, The Netherlands

Important Safety Instructions

1. Read these instructions.
2. Keep these instructions.
3. Heed all warnings.
4. Follow all instructions.
5. Do not use this apparatus near water.
6. Clean only with dry cloth.
7. Do not block any ventilation openings. Install in accordance with the manufacturer's instructions.
8. Do not install near any heat sources such as radiators, heat registers, stoves, or other apparatus (including amplifiers) that produce heat.
9. Do not defeat the safety purpose of the polarized or grounding-type plug. A polarized plug has two blades with one wider than the other. A grounding type plug has two blades and a third grounding prong. The wide blade or the third prong are provided for your safety. If the provided plug does not fit into your outlet, consult an electrician for replacement of the obsolete outlet.
10. Protect the power cord from being walked on or pinched particularly at plugs, convenience receptacles, and the point where they exit from the apparatus.
11. Only use attachments/accessories specified by the manufacturer.
12. Use only with the cart, stand, tripod, bracket, or table specified by the manufacturer, or sold with the apparatus. When a cart is used, use caution when moving the cart/apparatus combination to avoid injury from tip-over.



13. Unplug this apparatus during lightning storms or when unused for long periods of time.
14. Refer all servicing to qualified service personnel. Servicing is required when the apparatus has been damaged in any way, such as power-supply cord or plug is damaged, liquid has been spilled or objects have fallen into the apparatus, the apparatus has been exposed to rain or moisture, does not operate normally, or has been dropped.

Cautions for Safe Operation

Power Supply

This camera must always be operated DC 12 V or AC 24 V. Certified/Listed Adaptor which comply with LPS.

Handling of the unit

Be careful not to spill water or other liquids on the unit. Be cautious not to get combustible or metallic material inside the body. If used with foreign matter inside, the camera is liable to fail or to get cause of fire or electric shock.

- Remove dust or dirt on the surface of the lens with a blower.
- Use a dry soft cloth to clean the body. If it is very dirty, use a cloth dampened with a small quantity of neutral detergent then wipe dry.
- Avoid the use of volatile solvents such as thinners, alcohol, benzene and insecticides. They may damage the surface finish and/or impair the operation of the camera.

Operating and storage location

Avoid viewing a very bright object (such as light fittings) during an extended period. Avoid operating or storing the unit in the following locations.

- Extremely hot or cold places (operating temperature -10 °C to 50 °C, however, we recommend that the unit be used within a temperature range of 0 °C to 45 °C)
- Damp or dust place
- Places exposed to rain
- Places subject to strong vibration
- Close to generators of powerful electromagnetic radiation such as radio or TV transmitters.

Contents

Features	8	SENS-UP setting	20
Accessories.....	8	White Balance settings	21
Part Names and Functions	9	Day/Night Setting	21
Connections	10	SmartIR Setting	22
Precautions	10	Motion Detection Setting.....	23
Connecting Display device	10	3D-DNR Setting.....	24
Connecting RS-485 Device.....	11	Privacy Mask Setting	24
Connecting power source	11	Special Menu Settings	26
Connecting Waterproof processing of cable	12	D-ZOOM (Digital Zoom) Setting.....	26
Connecting Waterproof processing of cable	12	D-EFFECT (Digital effect) Setting	27
Menu Operation	13	SHARPNESS Setting	27
OSD Menu control buttons.....	13	COLOR Setting	28
OSD Menu Overview	14	SYNC Setting	28
General Operation.....	16	USER TITLE Setting.....	29
Exposure Settings.....	17	LANGUAGE Setting.....	29
Backlight setting	17	SYSTEM Setting	30
BRIGHTNESS setting.....	18	Specification	31
AGC (Automatic Gain Control) setting.....	19		
SHUTTER (Shutter Speed) setting.....	19		

Features



This IR Bullet Camera is designed for installation in a video surveillance system.

This manual contains instructions on how to install and manage the IR Bullet Camera in your video surveillance system.

Should you require any technical assistance, please contact authorized service center.

- High resolution and high sensitivity with a 6 mm (1/3 Type) Super HAD CCD II.
- Day & Night function.
- HSBLC/BLC covers various light conditions.
- Wide Dynamic Range (WDR)
- Weather Proof: IP66 Rating.

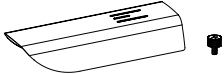
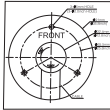
Accessories

Sunshield and Fixing screw	 A line drawing of a curved sunshield and a small black screw.
Installation sticker	 A circular diagram showing the camera's field of view and mounting points. The word 'FRONT' is written in the center. Arrows point to various parts of the diagram.
Wrench	 A line drawing of an L-shaped hex key wrench.
M3 Tapping Screws	 A line drawing of five different types of M3 tapping screws.

Part Names and Functions

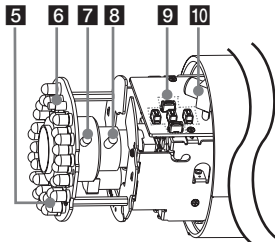
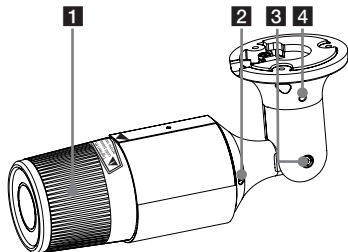

1 Lens Cover

2 Angle adjuster

Adjust the camera angle.

3 Tilt adjuster

Adjust the tilt position.

4 Pan adjuster

Adjust the pan position.

5 IR LED

6 IR Sensor

7 Focus lock lever

Fixes the focus position after adjusting.

8 Zoom lock lever

Fixes the zoom position after adjusting.

9 OSD menu control buttons

10 Video Out connector (BNC type)

Use this jack for checking the picture with portable monitor when install the camera.

Connections

Precautions

- Be sure to switch off the unit before installation and connection.
- The installation should be made by qualified service personnel or system installers.
- Do not expose the power and connection cables to moisture, which may cause damage to the unit.

Connecting Display device

The video signal connection between the camera and the monitor.

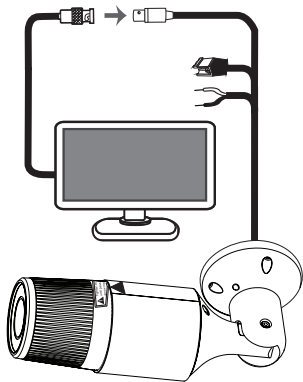

Connecting RS-485 Device

Use these ports to connect an external device of RS-485 format.

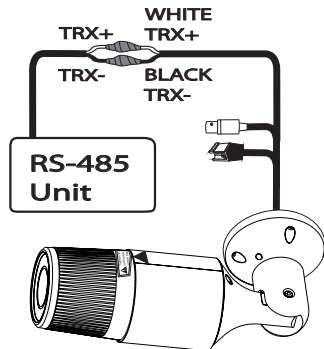

Connecting power source

Connect a power source to the input terminal with \oplus and \ominus aligned correctly, and then connect a power source to the power input terminal as shown below. (recommended power adapter is AC 24 V/0.5 A, DC 12 V/0.5 A or above)

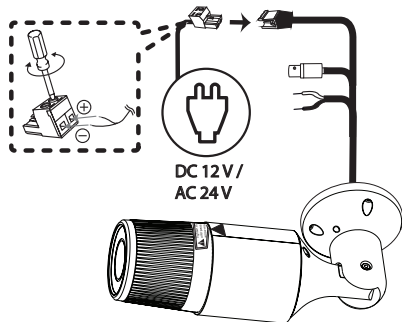

Connecting Waterproof processing of cable

Surely use the sealing tape.

1. Connect and tape the power cables.
2. Bind the power cables together with the tape.
3. Tape the BNC-BNC joint.

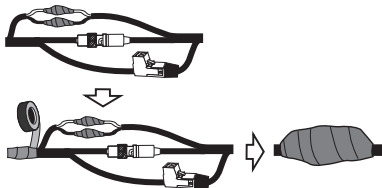

Warning:

- The cables are not waterproofed completely. So seal the tube ends and the portions between cable cores as well as connecting portions with tape.
- If not using the sealing tape, it may cause water absorption from a gap and finally condensation and water leakage.

Menu Operation

OSD Menu control buttons

This camera utilizes an on-screen user MENU. To set items on the menu, use the following buttons.

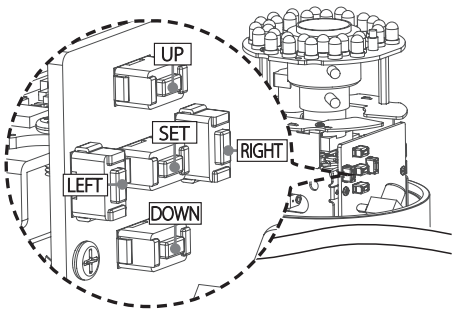

BUTTON	Description
UP	Used to move upper direction on the menu screen. Use this button to select an item or adjust the parameters.
DOWN	Used to move lower direction on the menu screen. Use this button to select an item or adjust the parameters.
RIGHT	Moves the cursor to the right. Used to increment the value selected in the menu. The parameter changes each time this button is pressed.
LEFT	Moves the cursor to the left. Used to decrement the value selected in the menu. The parameter changes each time this button is pressed.
SET	Executes selections and displays a submenu for an item with the  mark.

OSD Menu Overview

The following table shows the list of menu items and options. You can adapt the camera to your requirements by setting up the respective items in these menus.

Main Menu	Sub Menu	Contents	
EXPOSURE	ALC /ELC	BACKLIGHT	OFF/WDR/BLC/HSBLC
		BRIGHTNESS	0 to 100
		AGC	OFF/LOW/MIDDLE/HIGH
		SHUTTER	x512, ..., x2, AUTO, OFF, A.FLK, 1/160, ..., 1/120 000
		SENS-UP	OFF / AUTO
		EXIT	RET/ TOP / END
WHITE BAL	ATW	-	
	AUTO	-	
	AWC → SET KET	-	
	MANUAL	RED	-100 to 100
		BLUE	-100 to 100
EXIT		RET/ TOP / END	
DAY/NIGHT	AUTO	BURST	ON/OFF
		LEVEL	OW/ MIDDLE/ HIGH/USER
		DWELL TIME	3 SEC to 60 SEC
		EXIT	RET/ TOP / END

DAY/ NIGHT	EXT	BURST	ON/OFF	
		EXIT	RET/ TOP / END	
	DAY	-		
NIGHT	EXIT	BURST	ON/OFF	
		EXIT	RET/ TOP / END	
SMART IR	POSITION ↔	1 to 7		
	POSITION ↑↓	1 to 7		
	SIZE ↔	2 to 8		
	SIZE ↑↓	2 to 8		
	EXIT	RET/ TOP / END		
MOTION DET	OFF	-		
	ON	AREA SETUP	AREA SELECTION	1 to 8
			STATE	ON / OFF
			POSITION ↔	0 to 7
			POSITION ↑↓	0 to 5
			SIZE ↔	1 to 8
			SIZE ↑↓	1 to 6
			EXIT	RET/ TOP / END
	SENSITIVITY	0 to 100		
	DISPLAY	OFF / OUTLINE / MASK1 / MASK2		
	ALARM OUT	OFF / MESSAGE		
	EXIT	RET/ TOP / END		

3D-DNR	0 to 100	-		
PRIVACY MASK	OFF	-		
	ON	RECTANGLE	MASK SELECTION	1 to 8
			DISPLAY	OFF / MOSAIC / COLOR1 to COLOR8
			POSITION ←→	2 to 98
			POSITION ↑↓	2 to 98
			SIZE ←→	4 to 100
			SIZE ↑↓	4 to 100
			EXIT	RET/ TOP / END
			CIRCLE	MASK SELECTION
		DISPLAY		OFF / MOSAIC / COLOR1 to COLOR8
		POSITION ←→		0 to 100
		POSITION ↑↓		0 to 100
		SIZE ←→		1 to 15
		SIZE ↑↓		1 to 15
		RADIUS		0 to 100
	EXIT	RET/ TOP / END		

PRIVACY MASK	ON	POLYGON	MASK SELECTION	1 to 2
			DISPLAY	OFF / MOSAIC / COLOR1 to COLOR8
			SHAPE	-
			POSITION	-
			EXIT	RET/ TOP / END
SPECIAL	EXIT	RET/ TOP / END		
	D-ZOOM	OFF	-	
		ON	ZOOM	x 1.0 to x 16.0
			PAN	-100 to 100
			TILT	-100 to 100
			EXIT	RET/ TOP / END
	D-EFFECT	OFF / MIRROR / V-FLIP / ROTATE		
	SHARPNESS	0 to 100		
	COLOR	0 to 100		
	SYNC	INT / LL		
	USER TITLE	ON / OFF		
	LANGUAGE	ENG/CHN/KOR/JAP/FRE/ITA/SPA/POR/DUT/GER/POL/RUS/TUR/ARA/HEB		
	EXIT	RET/ TOP / END		

SYSTEM	FACTORY RESET	-	
	COMMUNICATION	CAMERA ID	OFF / 1 to 255
		PROTOCOL	LG / PELCO-D / PELCO-P
		BAUDRATE	2400 bps, 4800 bps, 9600 bps
		SAVE & REBOOT	-
EXIT	RET/TOP / END		
EXIT	-		

General Operation

1. Press [SET] button.
The Main OSD menu screen appears on the monitor.

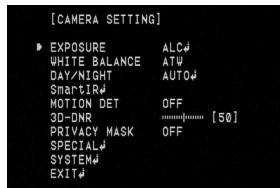

2. Use [UP] or [DOWN] button to select an option then press [SET] button.
Submenu appears on the monitor.
3. Use [UP] or [DOWN] button to select a submenu option.
4. Use [LEFT] or [RIGHT] button to select a value.
5. Select [EXIT] option then press [SET] to exit the setup menu. In the submenu, use [UP] or [DOWN] button to select the [RETURN] then press [SET] to return to the previous setup menu.
 - RETURN: Return to the previous.

- TOP: Return to the CAMERA SETTING menu screen.
- END: Exit the setup menu.

Exposure Settings

You can set the exposure options using the EXPOSURE menu.

1. Select [EXPOSURE] option on the [CAMERA SETTING] menu.
2. Use [LEFT] or [RIGHT] button to select a mode.
3. Press [SET] button and the EXPOSURE menu appears.

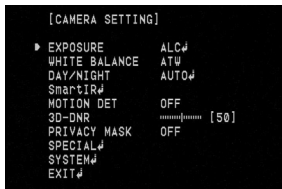

Note:

Select [ELC] mode on the [EXPOSURE] option for exact adjustment of focus. Change to [ALC] mode after adjustment.

Backlight setting

Use Backlight option to view the object clearly in backlight conditions.



1. Select [Backlight] option.
2. Use [LEFT] or [RIGHT] button to select a mode then press [SET].
 - WDR: WDR (Wide dynamic range) feature can be very helpful to cope with very challenging lighting conditions. It is capable of capturing both of the dark part and bright part and combining the differences into a scene to generate a highly realistic image as original scene. Set the WDR limit.
 - > ACE (Adaptive Contrast Enhancement) : This function is used when you want to display dark areas of WDR brightly.

- BLC: Camera's backlight compensation feature helps alleviate issues of visibility in high contrast areas. Set the BLC limit.

Note:

If the [DAY/NIGHT] option is set to [NIGHT] mode, the BLC mode of the [EXPOSURE] function is not available and [---] mark is displayed.

- HSBL: Use for masking brightness of the specific area to view the subject more clearly. The HSBL mode is automatically activated only in low luminance scene.
 - > AREA SETTING: Use [LEFT] or [RIGHT] button to select a area then use [UP] or [DOWN] button to select a [ON] or [OFF]. Press **[SET]** to exit the Area setting menu.
 - > GRAY SCALE: Use [LEFT] or [RIGHT] button to select a gray scale. (GRAY, D.GRAY, BLACK)
 - > USER SCALE: Use [LEFT] or [RIGHT] button to select a bright level. (5 level)
 - > MASK: Use [LEFT] or [RIGHT] button to select [ON] or [OFF].
If you set the MASK to ON, the mask function is activate only when the HSBL is automatically activated in low luminance scene.

- OFF: Not used.

BRIGHTNESS setting

You can increase the brightness of the darkened video. If you set the brightness to lower value, the image is darkened. If you set the brightness to higher value, the image gets bright.



1. Select [BRIGHTNESS] option.
2. Use [LEFT] or [RIGHT] button to set the bright level.

AGC (Automatic Gain Control) setting

If the images are too dark, change the maximum [AGC] value to make the images brighter. But noise is increase.



1. Select [AGC] option.
2. Use [LEFT] or [RIGHT] button to select a mode.

SHUTTER (Shutter Speed) setting

Select the desired shutter speed for camera exposure. You can change the shutter speed to higher speed to capture fast-moving subjects, though the image becomes darker.



1. Select [SHUTTER] option.
2. Use [LEFT] or [RIGHT] button to set shutter speed.

Notes:

- When the SHUTTER is set to AUTO, the picture may become unstable if the camera faces a bright fluorescent light directly. Therefore, take care when installing.
- Set the Shutter OFF when Color Rolling occurs in the indoor scene. Recommend the Shutter Auto in the outdoor scene.

- If you set to one of the SHUTTER options except AUTO, OFF and A.FLK on the [SHUTTER] menu, the [BACKLIGHT - WDR] setting is not available and [---] mark is displayed.
- If you set BACKLIGHT mode to WDR, sub menu [SHUTTER LIMIT] of [SHUTTER AUTO] will be blocked and shutter will be fixed. (LCU5500R-BN : 1/60, LCU5500R-BP : 1/50)

SENS-UP setting

If pictures are not clear due to darkness, this SENS-UP operation would increase the sensitivity of picture.



1. Use [UP] or [DOWN] button to select [SENS-UP] option.
2. Use [LEFT] or [RIGHT] button to select mode.
 - AUTO: Adjust the sensitivity of the picture automatically.
 - > SENS-UP LIMIT: Use [LEFT] or [RIGHT] button to set the SENS-UP limit.
 - OFF: Not used.

Note:

If you set to one of the SHUTTER options except AUTO and [OFF] on the [SHUTTER] menu, the [SENS-UP] setting is not available and [---] mark is displayed.

White Balance settings

Select the method by which the camera shifts its output colors to compensate for the color of a light source.

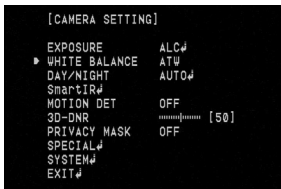

1. Select [WHITE BAL] option.
2. Use [LEFT] or [RIGHT] button to select a mode then press [SET].
 - ATW (Auto-Tracing White Balance): Use [LEFT] or [RIGHT] button to select the ATW then press [SET] button.
 - MANUAL: You can set the white balance options manually.
 - > RED: Obtains the optimum amount of red gain.
 - > BLUE: Obtains the optimum amount of blue gain.

- AWC→SET KEY: If you select the AWC→SET KEY mode, you will be able to set up the White Balance automatically using [SET] button.
- AUTO : Use [LEFT] or [RIGHT] button to select the AUTO then press [SET] button.

Day/Night Setting

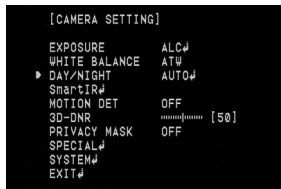

1. Select [DAY/NIGHT] option.
2. Use [LEFT] or [RIGHT] button to select mode for Day/Night function.
 - AUTO: You will be able to change the Day/Night mode automatically.

Note:

If you set the AGC to [OFF] on the [EXPOSURE] menu, the AUTO mode of the DAY/NIGHT function is not available and [---] mark is displayed.

- > BURST: Use [LEFT] or [RIGHT] button to select [ON] or [OFF].
- > LEVEL: Use [LEFT] or [RIGHT] button to select a level.
- > DWELL TIME: Use [LEFT] or [RIGHT] button to select a dwell time.
- EXT: Switches between color picture and black and white picture when an external day / night switching signal is received.
 - > BURST: Use [LEFT] or [RIGHT] button to select [ON] or [OFF].
- DAY: Color mode enabled.
- NIGHT: Black-and-white mode enabled.
 - > BURST: Use [LEFT] or [RIGHT] button to select [ON] or [OFF].

SmartIR Setting

SmartIR function improve the sensitivity in the low luminance. SmartIR analyze the image of the screen, when the subject is close. Then SmartIR reduce the IR LED brightness and gain to prevent saturation of the closed subject.

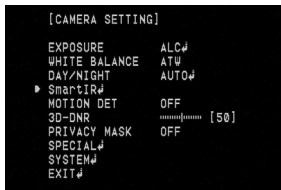

1. Select [SmartIR] option.
2. Use [UP] or [DOWN] to select an option then use [LEFT] or [RIGHT] button to adjust the option.
 - POSITION \leftrightarrow : Moves horizontal position of the prevent saturation zone.
 - POSITION \updownarrow : Moves vertical position of the prevent saturation zone.
 - SIZE \leftrightarrow : Enlarge or decrease the horizontal size of the prevent saturation zone.

- SIZE \updownarrow : Enlarge or decrease the vertical size of the prevent saturation zone.

Motion Detection Setting

The motion detection detects the moving objects in the scene by monitoring changes in brightness level. You can select the level of sensitivity for motion detection to 8 zone.

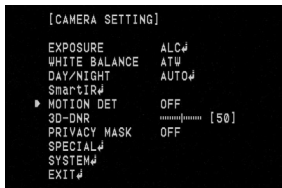

1. Select [MOTION DET] option.
2. Use [LEFT] or [RIGHT] button to select a [ON] and press [SET]. The MOTION DETECTION menu appears.
3. Select [AREA SETUP] option.
 - Use [LEFT] or [RIGHT] button to select a area (1/8 to 8/8) on the [AREA SELECTION].
 - Use [LEFT] or [RIGHT] button to set up the ON or

OFF on the STATE.

- Use [UP] or [DOWN] to select an option then use [LEFT] or [RIGHT] button to adjust the option.
 - > POSITION \leftrightarrow : Moves horizontal position of the mask.
 - > POSITION \updownarrow : Moves vertical position of the mask.
 - > SIZE \leftrightarrow : Enlarge or decrease the horizontal size of the mask.
 - > SIZE \updownarrow : Enlarge or decrease the vertical size of the mask.
4. Use [SENSITIVITY] option to obtain the optimum detection level.
 5. Use [LEFT] or [RIGHT] button to select the DISPLAY option.
 6. Use [LEFT] or [RIGHT] button to select the ALARM OUT option.

3D-DNR Setting

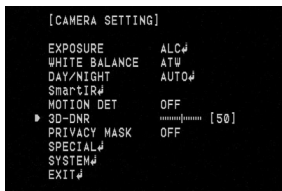

1. Select [3D-DNR] option.
If pictures are not clear due to brightness, this option would reduce the noise of picture.
2. Use [LEFT] or [RIGHT] button to select a value.

Privacy Mask Setting

This function is aiming at the protection of personal privacy, selecting a screen part black not to be displayed in the screen. Up to 14 zones can be registered.

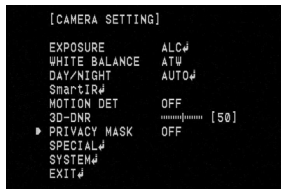

1. Select [PRIVACY] option.
2. Use [LEFT] or [RIGHT] button to select a [ON] and press [SET]. The PRIVACY SETUP menu appears.
 - RECTANGLE :
 - > Use [LEFT] or [RIGHT] button to select a mask (MASK1 to MASK8) on the [MASK SELECTION].
 - > Use [LEFT] or [RIGHT] button to set up the OFF, MOSAIC, COLOR 1 to COLOR 8 on the DISPLAY option.
 - > Use [UP] or [DOWN] to select an option then

use [LEFT] or [RIGHT] button to adjust the option.

- POSITION \leftrightarrow : Moves horizontal position of the mask.
- POSITION \updownarrow : Moves vertical position of the mask.
- SIZE \leftrightarrow : Enlarge or decrease the horizontal size of the mask.
- SIZE \updownarrow : Enlarge or decrease the vertical size of the mask.

• CIRCLE :

- > Use [LEFT] or [RIGHT] button to select a mask (MASK1 to MASK4) on the [MASK SELECTION].
- > Use [LEFT] or [RIGHT] button to set up the OFF, MOSAIC, COLOR 1 to COLOR 8 on the DISPLAY option.
- > Use [UP] or [DOWN] to select an option then use [LEFT] or [RIGHT] button to adjust the option.
 - POSITION \leftrightarrow : Moves horizontal position of the mask.
 - POSITION \updownarrow : Moves vertical position of the mask.

- SIZE \leftrightarrow : Enlarge or decrease the horizontal size of the mask.
- SIZE \updownarrow : Enlarge or decrease the vertical size of the mask.
- RADIUS SIZE : You can adjust the RADIUS SIZE (0 to 100).

• POLYGON :

- > Use [LEFT] or [RIGHT] button to select a mask (MASK1 to MASK2) on the [MASK SELECTION].
- > Use [LEFT] or [RIGHT] button to set up the OFF, MOSAIC, COLOR 1 to COLOR 8 on the DISPLAY option.
- > Use the [LEFT], [RIGHT], [UP], [DOWN], [SET] button to draw the polygon on the [SHAPE].
- > Use the [LEFT], [RIGHT], [UP], [DOWN], [SET] button to move the polygon on the [POSITION].

Note:

You can adjust the mask color manually except for color 8.

Special Menu Settings

This menu lets you adjust and set up D-ZOOM, D-EFFECT, SHARPNESS, COLOR, SYNC, USER TITLE, LANGUAGE function by yourself in the SPECIAL menu.

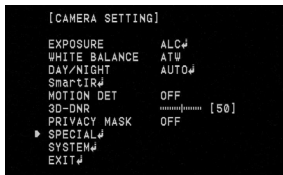

1. Select [SPECIAL] option.
2. Press [SET] button and the SPECIAL menu appears.

D-ZOOM (Digital Zoom) Setting

You can select the digital zoom level.



1. Select [D-ZOOM] option on the [SPECIAL] menu.
2. Use [LEFT] or [RIGHT] button to select a [ON] then press [SET] the DIGITAL ZOOM menu appears. When you set to ON, the displayed image can be shaking.
3. Use [UP] or [DOWN] to select a option then use [LEFT] or [RIGHT] button to select a level.
 - ZOOM: Use [LEFT] or [RIGHT] button to enlarge the screen.
 - PAN: Use [LEFT] or [RIGHT] button to move the screen.

- TILT: Use [LEFT] or [RIGHT] button to move the screen.

Note:

If you set the [D-ZOOM] to ON, the ZOOM level is set to [x1.0] automatically.

D-EFFECT (Digital effect) Setting

You can select the digital effect.



1. Select [D-EFFECT] option on the [SPECIAL] menu.
2. Use [LEFT] or [RIGHT] button to select a digital effect.
 - V-FLIP: Flip the picture vertically.
 - ROTATE: Rotate the picture. (180°)
 - MIRROR: Turn on the mirror effect.
 - OFF: Turn off the digital effect.

SHARPNESS Setting

The degree to which the boundary of the two portions is clearly distinguished.



1. Select [SHARPNESS] option on the [SPECIAL] menu.
2. Use [LEFT] or [RIGHT] button to change a adjust the option. If you set the sharpness value to higher, the image outline becomes sharp. If you set to lower value, the image outline becomes dim.

COLOR Setting

You can switch the displayed picture to gray scale or color.



1. Select [COLOR] option on the [SPECIAL] menu.
2. Use [LEFT] or [RIGHT] button to change a adjust the option.

SYNC Setting



1. Select [SYNC] option on the [SPECIAL] menu.
2. The [SYNC] option is set to [INT] automatically.

USER TITLE Setting

You can use the camera identification to assign a number and character to the camera. To disappear the user title, select [OFF].

1. Select [USER TITLE] option on the [SPECIAL] menu.
2. Use [LEFT] or [RIGHT] button to select a [ON] then press [SET]. The USER TITLE menu appears.

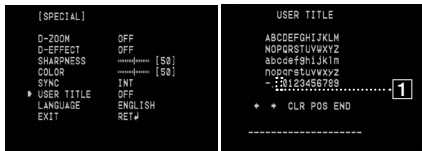

3. Use [UP], [DOWN], [LEFT] or [RIGHT] button to select a character or number then press [SET] button.
 - CLR: Clear all entered characters and numbers.
 - POS: Move the USER TITLE position on the screen using the arrow buttons.
 - END: Confirm your selection or exit the setting
 - **1** (Blank): Inserts a space at the cursor position.
 - **←/→**: Moves cursor to left or right.

LANGUAGE Setting

Select the viewer language for the camera setup menu and OSD information display.



1. Select [LANGUAGE] option on the [SPECIAL] screen.
2. Press [LEFT] or [RIGHT] button to select a language.

SYSTEM Setting

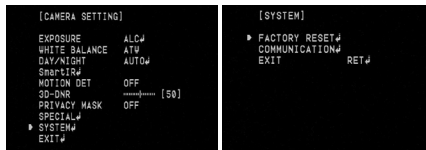

1. Select the [SYSTEM] menu.
2. Press [SET] button and the SYSTEM menu appears.
3. Use [UP] or [DOWN] button to select the option.
 - **FACTORY RESET:** To reset the camera setting to factory setting, select the [FACTORY RESET] option.
 - **COMMUNICATION**
 - > **CAMERA ID:** You can use the camera identification [CAMERA ID] to assign a number to the camera. Use [LEFT] or [RIGHT] to select a CAMERA ID.
 - > **PROTOCOL:** Select a protocol for RS-485 communication.
 - > **BAUD RATE:** Set the speed of communication between the camera and the RS-485 unit.

- > **SAVE & REBOOT:** To confirm the communication settings.

4. Press [SET] button to confirm your selection.

Notes:

- You need to set up [Save & Report] for save [Camera ID], [Protocol], [Baud & Rate] changes.
- The menu screen is move to top menu, after set up [Factory Reset].

Specification

Item		LCU5500R-BN	LCU5500R-BP
Signal System		NTSC	PAL
Image Sensor		6 mm (1/3 Type) Super HAD CCD II	
Lens		2.8 mm to 11 mm Vari-focal Lens, F1.2	
Horizontal Resolution	Color	650 TV Lines	
	B/W	700 TV Lines	
Day & Night		ICR (AUTO / DAY / NIGHT)	
Sens-up		OFF / AUTO(x2, ... x512)	
Minimum Illumination (30 IRE)	Color	0.2 lx @ Sens-up OFF, F1.2	
	B / W	0 lx @ IR LED ON	
S/N Ratio		50 dB	
Digital Zoom		X16	
Sync. System		Internal / Line Lock	
Video Output		1 Vp-p Composite (75 Ω)	
Electronic Shutter		1/60 to 1/120 000	1/50 to 1/120 000
Motion Detection		8 Zones	
IR LED		IR LED 32 EA, 50 M Distance, SmartIR	

Item		LCU5500R-BN	LCU5500R-BP
Communication		RS-485, Coaxial Communication	
RS-485		LG, Pelco-D, Pelco-P	
Backlight Compensation		OFF / WDR / BLC / HSBLC	
Privacy Masking		14 Masks	
DNR		2D + 3D-DNR	
Protection		IP66	
Power Source		DC 12 V / AC 24 V	
Power Consumption	DC 12 V	490 mA	
	AC 24 V	390 mA	
Operating Temperature/ Humidity		-10 °C to 50 °C / 0 % RH to 80 % RH	
Storage Temperature/ Humidity		-20 °C to 60 °C / 0 % RH to 90 % RH	
Dimension (W x H x D)		84 mm x 83.5 mm x 320 mm	
Weight		1.3 kg	

