



VOPEX® Series

VOPEX-C6DVI(A)-x DVI Video/Audio or DVI Video Only Splitter/Extender Installation and Operation Manual



VOPEX-C6DVI(A)-LA-4 (Front and Rear View)



ST-C6DVI(A)-IR-300 Remote Unit
(not included)

TRADEMARK

VOPEX is a registered trademark of Network Technologies Inc in the U.S. and other countries.

COPYRIGHT

Copyright © 2003, 2013 by Network Technologies Inc. All rights reserved. No part of this publication may be reproduced, stored in a retrieval system, or transmitted, in any form or by any means, electronic, mechanical, photocopying, recording, or otherwise, without the prior written consent of Network Technologies Inc, 1275 Danner Drive, Aurora, Ohio 44202.

CHANGES

The material in this guide is for information only and is subject to change without notice. Network Technologies Inc reserves the right to make changes in the product design without reservation and without notification to its users.



WARNING: Never connect a VOPEX Series VOPEX-C6DVI(A)-(LA) -x Extender/Splitter to an Ethernet card, Ethernet router, hub or switch or other Ethernet RJ45 connector of an Ethernet device. Damage to devices connected to the Ethernet may result.

Note: CATx connection cable used between NTI XTENDEX Series Local and Remote or any XTENDEX Series products should not be run underground, outdoors or between buildings.



WARNING: Outdoor or underground runs of CATx cable could be dangerous and will void the warranty.

TABLE OF CONTENTS

Introduction.....	1
Materials.....	2
Features and Functions.....	3
Limitations.....	5
Preparation for Installation.....	5
VOPEX Installation.....	6
VOPEX-C6DVI(A)-x.....	6
VOPEX-C6DVI(A)-LA-x.....	7
Remote Unit Installation.....	8
ST-C6DVI(A)-R-300.....	8
Connect the CATx cable.....	9
Infrared Control.....	10
Plug-in and Boot Up.....	11
Cascading.....	12
Technical Specifications.....	13
Interconnection Cable Wiring Method.....	15
RJ45 Connector Wiring.....	15
Troubleshooting.....	15
Warranty Information.....	16

TABLE OF FIGURES

Figure 1- Connecting the VOPEX to a video/audio source.....	6
Figure 2- Connect Local User components to VOPEX-C6DVI(A)-LA-4.....	7
Figure 3- Connect the Extended Components to the ST-C6DVI(A)-R-300 Remote Unit.....	8
Figure 4- Connect a CATx cable between the VOPEX and each Remote Unit.....	9
Figure 5- Connect IR Emitter and Receiver.....	10
Figure 6- Connect the AC adapter to a VOPEX.....	11
Figure 7- Cascaded VOPEX configuration.....	12
Figure 8- View looking into RJ45 female.....	15

INTRODUCTION

The VOPEX® Series Cat5 DVI DVI Splitter/Extender (VOPEX) simultaneously distributes high resolution single link digital DVI video from one video source to 4, 8, or 16 displays, each located up to 300 feet away using a single CAT5e/6/6A/7 (CATx) cable.

Remote video and audio devices can be located as much as 300 feet away from the source via Category 5e/6/6A/7 unshielded or shielded (see chart on page 14) twisted-pair cable. The VOPEX can optionally supply video and audio to devices located near the source.

Options:

VOPEX-C6DVI(A)-x Video/Audio Splitter/Extender for DVI video and line level analog audio

VOPEX-C6DVI(A)-LA-x Video/Audio Splitter/Extender with support local video and audio (when supported) access

x= 4,8, or 16 for the number of Remote Units that can be connected.

Note: If the audio support is not present, please disregard all audio references.

The VOPEX-C6DVI DVI Splitter/Extender via CATx will broadcast real-time information to multiple remote monitors simultaneously. This high-resolution DVI video splitter (video port expander) is the ideal solution for any application requiring the flexibility to share information with several locations. Optional audio functionality using self-powered stereo speakers enhances your presentation.

Possible digital video and audio sources include a DVD player, cable television box, home entertainment system, etc.. Digital audio devices include a HDTV, Home Theater System, Digital Audio Receiver, or Digital Speaker set etc.. Some stereo line-level audio source and devices include HDTV Speakers, Home Theater or Stereo System, Stereo Amplifier, Headphones, and Computer Speakers.

The VOPEX Series DVI Splitter/Extender is extremely simple to install and has been thoroughly tested to insure reliable performance. Through the use of CATx unshielded twisted-pair cable it is possible to economically increase the flexibility of a computer/home entertainment system. Here are some of the features and ways this can benefit the user:

- Allows the placement of monitors/HDTVs and self-powered stereo speakers/amplifiers in different remote locations where only these parts are needed.
- Video quality adjustment is automatic for varying lengths of CATx cable
- Digital transmission of audio signals reduces any loss in quality.
- Compatible with all NTI A/V switches and splitters, enabling the joining of products to create a system that satisfies all networking needs.
- Broadcast real-time DVI video to multiple display locations.
- Supports HDTV resolutions to 1080p and computer resolutions to 1920x1080 and 1920x1200.
- HDCP compliant.
- Supports the DDC2B protocol.
- Full IR control of DVI source from remote HDTV using existing source remote control.
- EDID learning for the support of any DVI display device.
- Supplies power to the remote units – no additional power supplies required.
- Optional audio can be broadcast to self-powered stereo speakers at each remote location and optionally to the local unit.
- Available with optional local access support for local DVI display.
- Cascade multiple units for more numerous display configurations.
- Ideal for digital signage, tradeshow, or classrooms where high quality video on multiple monitors is needed.

MATERIALS

Materials Included with this kit:

- VOPEX-C6DVI(A)-(LA)-4/8/16
- 120VAC or 240VAC at 50 or 60Hz-24VDC/2.5A AC Adapter (4 and 8 port models only)
- Line cord, country specific
- DVI-IS-3-MM 3 Foot DVI Male-Male Single-Link Cable
- SA-3-MM 3 Foot 3.5mm stereo plug -stereo plug cable (only models with audio option)
- CD with a pdf file of this manual
- 3 Foot IR-EMITTER (IR-EMTR-3)

Legend:

- x= 4, 8, or 16 for number of ports
- MM- indicates male-male connectors

Additional materials not supplied but are required:

- CAT5e Solid/Stranded UTP (350MHz or better) or CAT6/6a solid UTP or CAT7 Solid/Stranded STP cable(s) terminated with RJ45 connectors wired straight thru- pin 1 to pin 1, etc. (see page 15 for proper EIA/TIA 568B wiring method)
- One or more of the following XTENDEX Remote Units:

Remote Unit	For use with
ST-C6DVI-IR-300	VOPEX-C6DVI(A)-(LA)-x
ST-C6DVIA-IR-300	VOPEX-C6DVIA-(LA)-x

Contact your nearest NTI distributor or NTI directly for all of your KVM needs at 800-RGB-TECH (800-742-8324) in US & Canada or 330-562-7070 (Worldwide) or at our website at www.networktechinc.com and we will be happy to be of assistance.

- Cables for connecting the HD video and stereo audio devices to the VOPEX :

Cables available from NTI

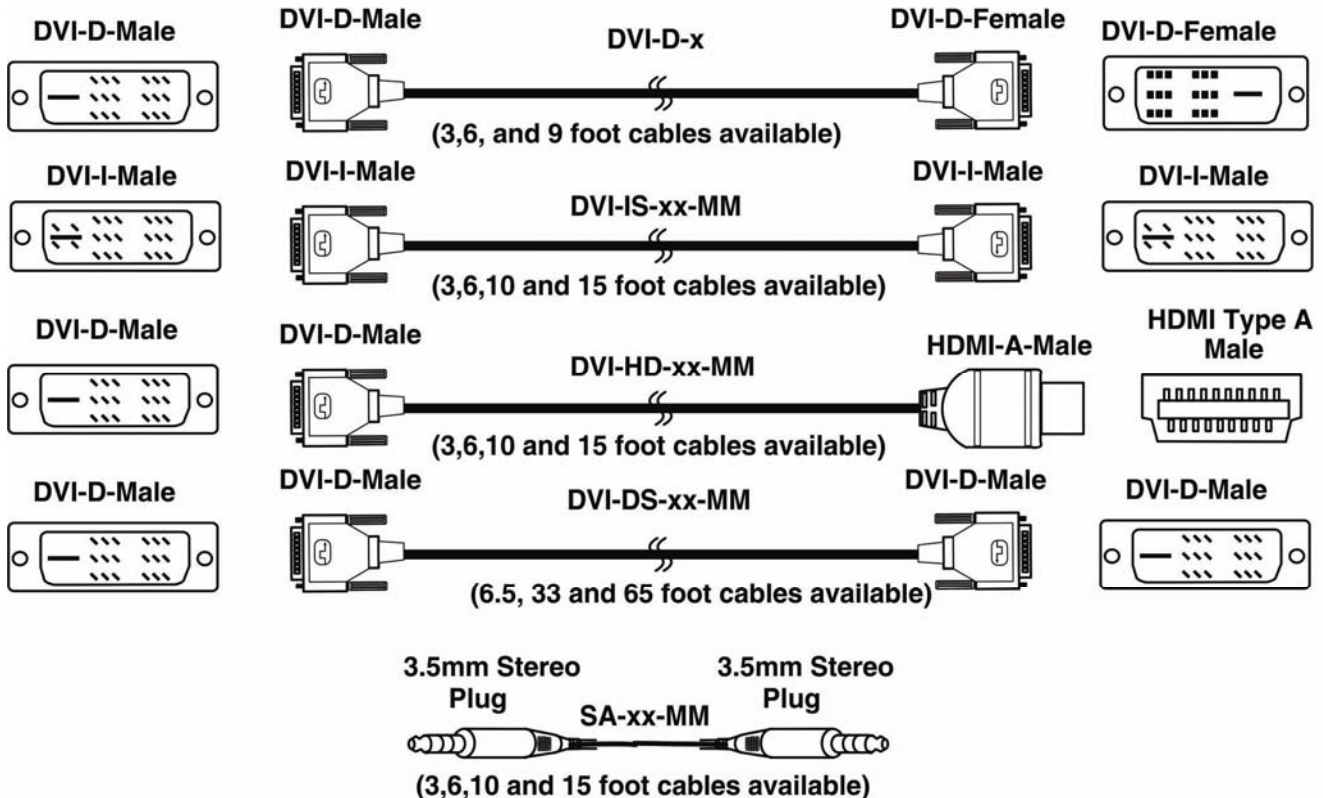

FEATURES AND FUNCTIONS

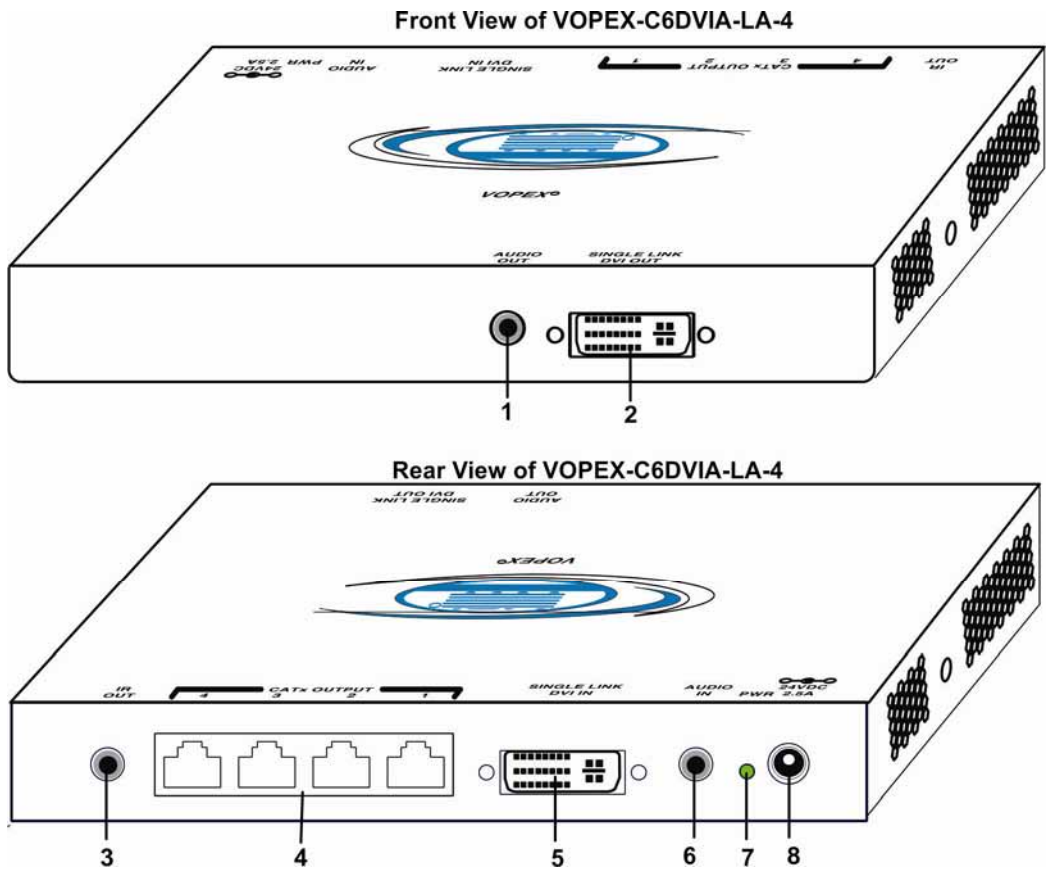

VOPEX

#	LABEL	CONNECTOR	DESCRIPTION
1	Audio Out	3.5mm Stereo jack	For connecting self-powered stereo speakers (models with Audio support and Local Access feature only)
2	Single Link DVI Out	DVI female video connector	for connecting the local display device (only models with Local Access feature)
3	IR Out	3.5mm Stereo Jack	for connecting the IR Emitter
4	CATx Output 1-4	RJ45 connector	for connecting the CAT5e/6/6a/7 cable between the VOPEX and Remote units
5	Single Link DVI In	DVI female video connector	for connecting an DVI cable between the VOPEX and the video source
6	Audio In	3.5mm Stereo jack	For connecting to stereo audio source (models with Audio support only)
7	Pwr	Green LED	Illuminates when power has been applied to the VOPEX
8	24VDC- 2.5A	1.0mm Power Jack	connection jack for the AC adapter (Only on 4 and 8 port models. 16 port model has IEC connector for country specific line cord)

XTENDEX Remote Unit (Sold Separately)

ST-C6DVIA-IR-300 Remote Unit

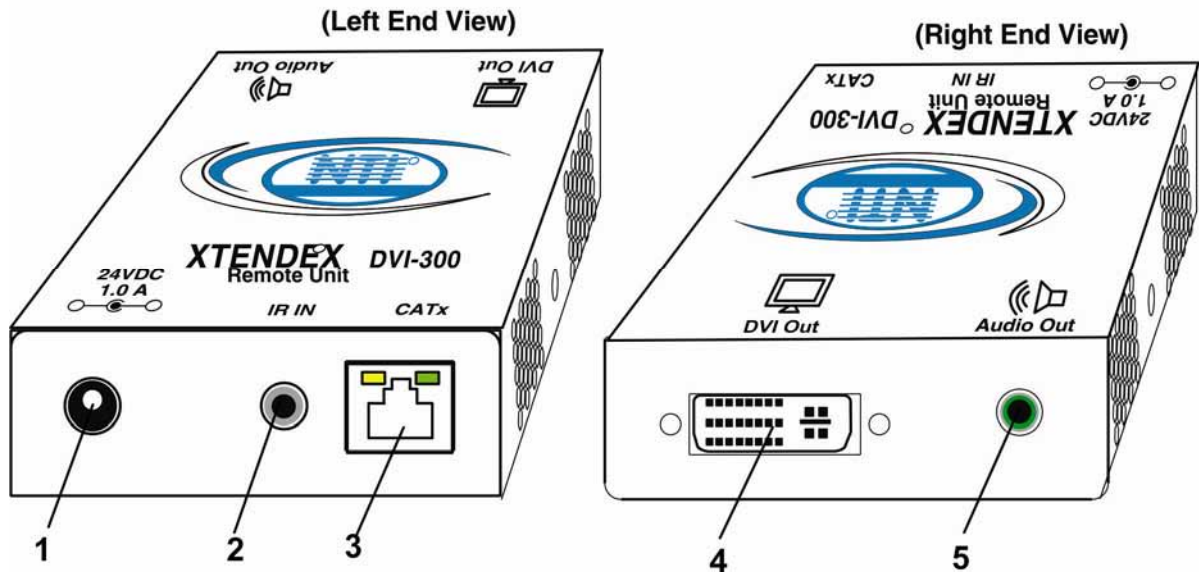

#	LABEL	CONNECTOR	DESCRIPTION
1	24VDC 1.0A	1.0mm Power Jack	Not used in this application
2	IR In	3.5mm Stereo Jack	for connecting the IR Receiver
3	CATx	RJ45 Female	for connecting the CAT5e/6/6a/7 cable between the VOPEX and Remote unit
3a	Yellow LED	--	traffic indicator - illuminates when there is communication between the VOPEX and Remote Units.
3b	Green LED	--	power indicator - illuminates when power has been supplied to the unit
4	DVI Out	DVI female video connector	for connecting the remote display device
5	Audio Out	3.5mm Stereo Jack	For connecting self-powered stereo speakers

LIMITATIONS

- The audio input of the VOPEX-C6DVIA-(LA)-x is compatible with the following standard CPU audio outputs:
 - Line out - typically lime green in color
 - Speaker out- typically orange in color
 - Headphone out- typically located on the CD-ROM
- The audio outputs of the VOPEX and the XTENDEX Remote Unit are compatible with self-powered stereo speakers.

PREPARATION FOR INSTALLATION

- Locations should be chosen for the monitors and speakers that also have space to connect the VOPEX and XTENDEX Remote Units within the distance provided by the cables. If extension cables are needed, contact NTI for the cables required.
- The CAT5 cables must be run to the locations where the VOPEX and XTENDEX Remote Units will be connected. Be careful to route the cables away from any sources of magnetic fields or electrical interference that might reduce the quality of the video signal (i.e. AC motors, welding equipment, etc.). **NOTE:** If CAT5 cable is already installed in the wall and there are RJ45 wall outlets, it will be necessary to obtain male-to-male straight through connection cables long enough to reach from the wall outlets to the connection locations of the VOPEX and XTENDEX Remote Units.
- A properly grounded, polarized, and preferably surge-protected 120V or 240V electrical outlet (depending on the AC adapter being used) must be installed close enough to the connection location of the VOPEX and XTENDEX Remote Units, monitors, stereo speakers, and CPU to plug them into.
- All cables should be installed in such a way that they do not cause stress on their connections to the equipment. Extended lengths of cable hanging from a connection may interfere with the quality of that connection. Secure cables as needed to minimize this.
- Properly shut down and disconnect the power from all devices to be separated. If other equipment is involved whose connections are being interrupted, be sure to refer to the instruction manuals for that equipment for proper disconnection and re-connection procedures before proceeding.

Note: *CAT5 connection cable used between NTI XTENDEX Series Local and Remote or any XTENDEX Series products should not be run underground, outdoors or between buildings.*



WARNING: *Outdoor or underground runs of CAT5 cable could be dangerous and will void the warranty.*

VOPEX INSTALLATION

VOPEX-C6DVI(A)-x

Note: VOPEX-C6DVI-x Video Only Splitter/Extender does not have audio support. If the audio support is not present, please disregard all audio references.

1. Make connections between the VOPEX and the audio and video source(s). (See Fig. 1.)
 - a) Connect one end of the DVI-IS-3-MM (supplied) to the DVI connector on the video source.
 - b) Connect the other end of the DVI-IS-3-MM cable to the DVI female connector marked "DVI Video In" on the VOPEX.
 - c) Connect one 3.5mm stereo plug end of the SA-3-MM cable (supplied) into the 3.5mm female audio connector marked "line out", "spkr", or "headphones" on the audio source.

Notes:

If all 3 connectors are available, use the connector marked "line out".

The "line out" connector is typically lime green and may be marked with this symbol 

The "spkr" connector is typically orange, and may be marked with this symbol 

The "headphones" connector may be marked with this symbol 

- d) Connect the other 3.5mm stereo plug end of the SA-3-MM cable into the 3.5mm female stereo audio connector marked "Audio In" on the VOPEX.

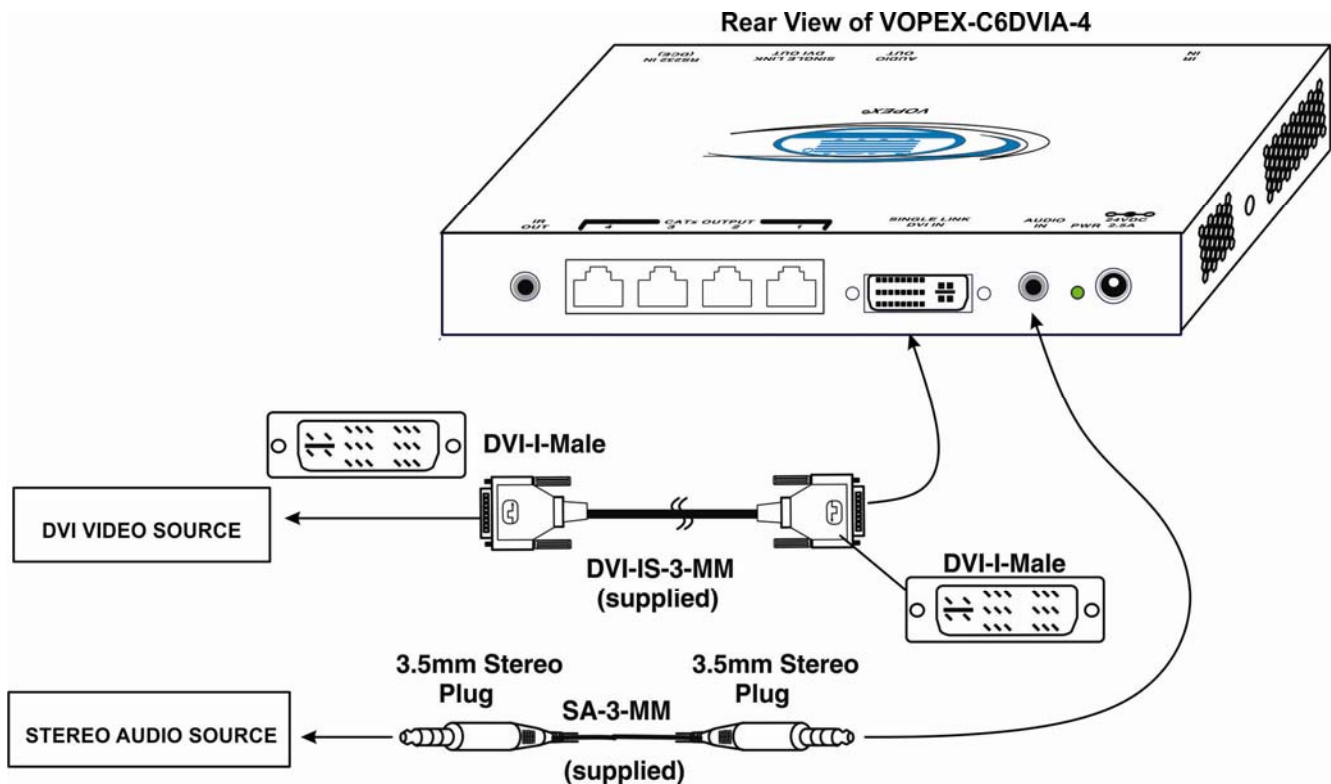

Figure 1- Connecting the VOPEX to a video/audio source

VOPEX-C6DVI(A)-LA-x

Once the DVI video and stereo audio source connections have been made, if the Local Access (LA) option is present, a monitor and (where applicable) self-powered stereo speakers can be connected.

1. Connect the cable from the local user's HDTV display to the DVI female connector marked "DVI Video Out" on the VOPEX.
2. Connect the cable from the local speakers into the 3.5mm stereo audio connector marked "Audio Out" on the VOPEX.

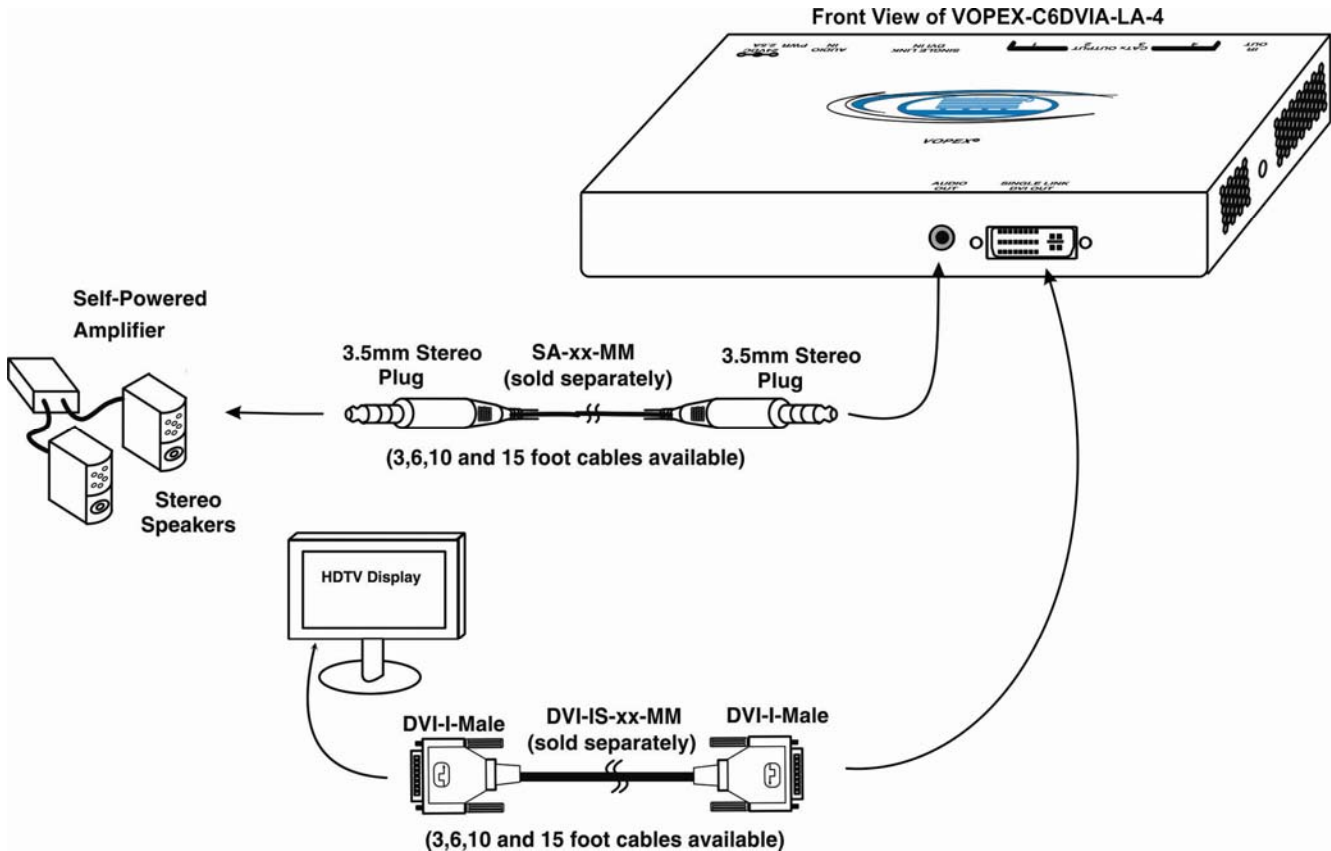

Figure 2- Connect Local User components to VOPEX-C6DVI(A)-LA-4

REMOTE UNIT INSTALLATION

ST-C6DVI(A)-R-300

1. Position a ST-C6DVI(A)-R-300 Remote Unit such that the CATx cable, the monitor cable, and speaker cable can each reach the Remote Unit comfortably.
2. Connect the remote user's monitor cable to the female DVI video connector on the Remote Unit.
3. Connect the remote user's speakers (where applicable) to the 3.5mm female stereo connector on the Remote Unit.

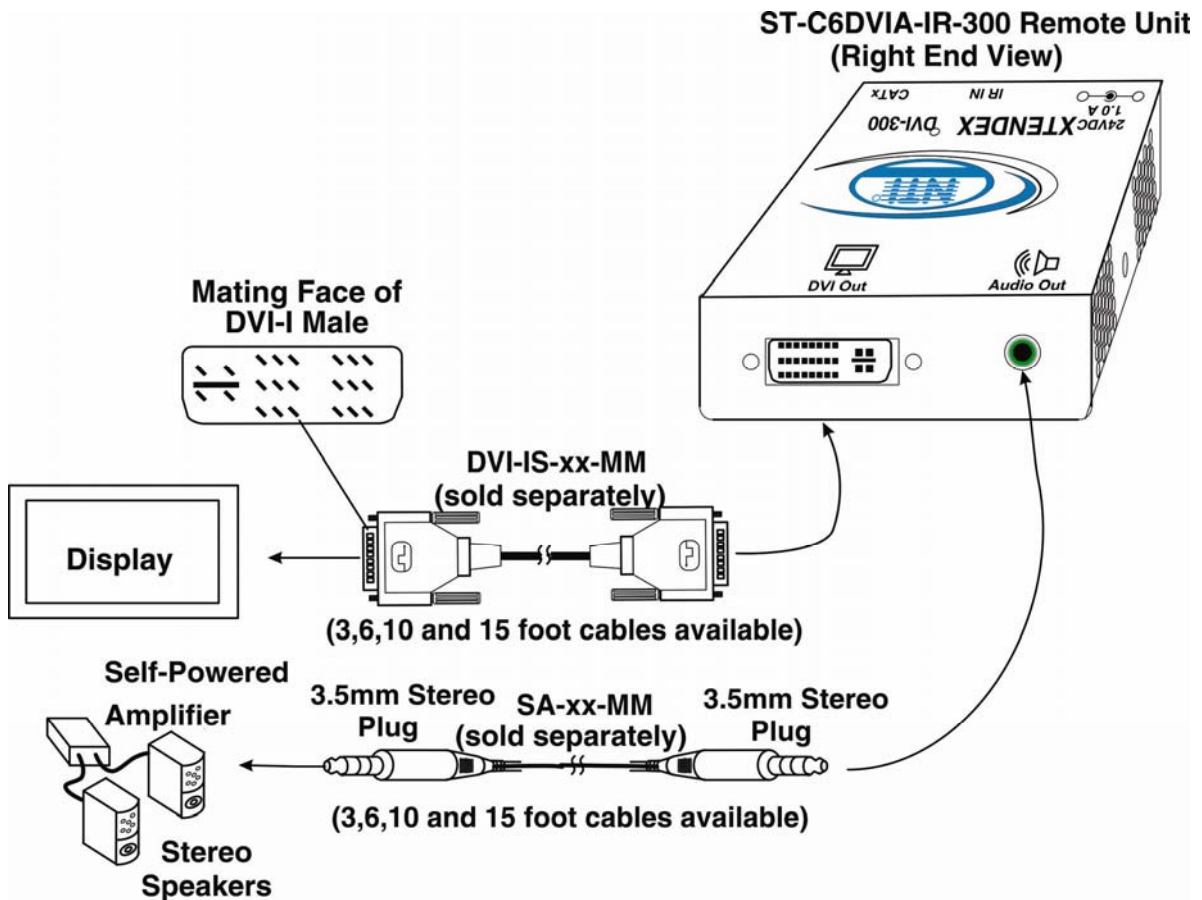

Figure 3- Connect the Extended Components to the ST-C6DVI(A)-R-300 Remote Unit

CONNECT THE CATX CABLE

Make sure the CATx cable has been installed in accordance with the “Preparation for Installation” instructions on page 5. Connect a CATx cable to one of the ports marked “CATx Output” on the VOPEX. Connect the other end of that cable to the “Cat x” port on a Remote Unit. When properly inserted the CATx cable end should snap into place.

Repeat for each remote unit installed.



WARNING: Never connect the XTENDEX to an Ethernet card, Ethernet router, hub or switch or other Ethernet RJ45 connector of an Ethernet device. Damage to devices connected to the Ethernet may result.

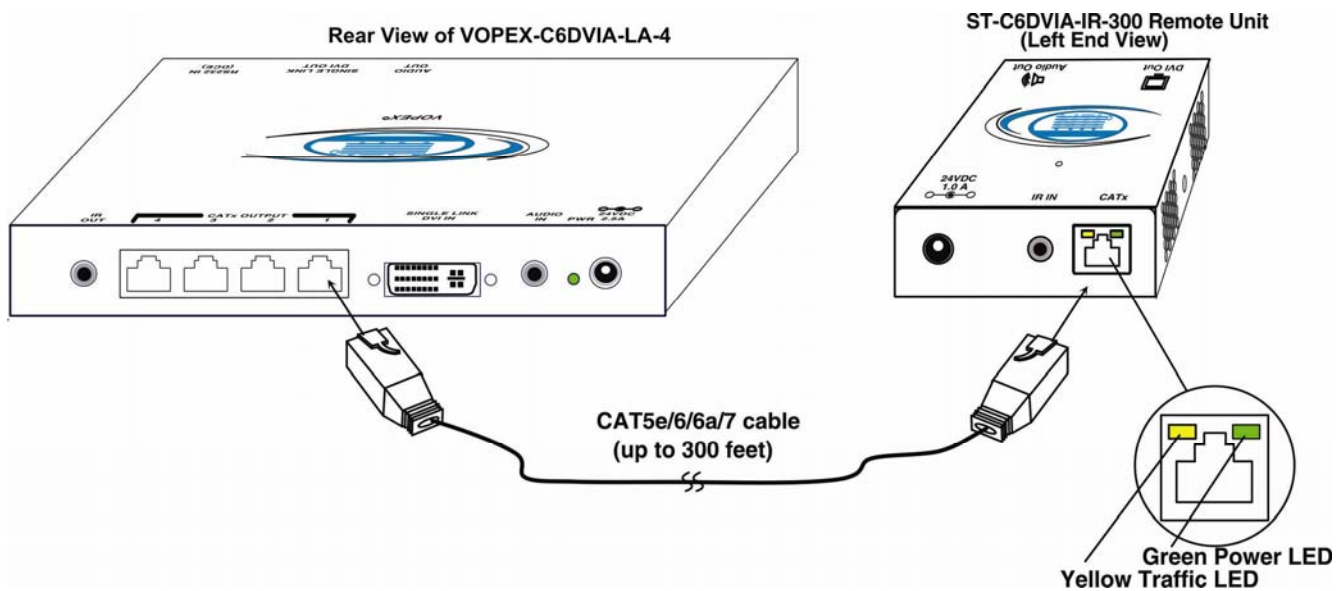

Figure 4- Connect a CATx cable between the VOPEX and each Remote Unit

INFRARED CONTROL

The VOPEX includes a port for connecting an infrared emitter that when used with an infrared receiver (connected at the Remote Unit end) will work in conjunction with the IR remote control used to operate the video/audio source. Connect the receiver to the "IR IN" port on the Remote Unit and the emitter to the "IR OUT" port on the VOPEX. Position the end of the receiver such that the signal from the remote control can easily reach the IR sensor. Position the end of the emitter such that the extended signal can be sent to the signal source.

Note: The IR Emitter and Receiver work within a frequency range of 30-60kHz. Check the specifications for the device you are extending to make sure the VOPEX and XTENDEX will work with it.

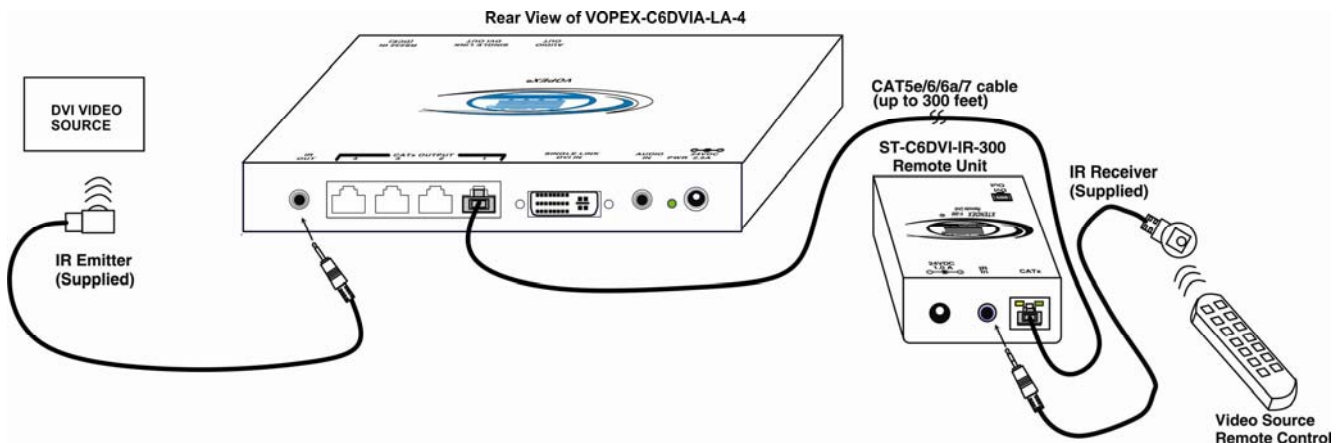
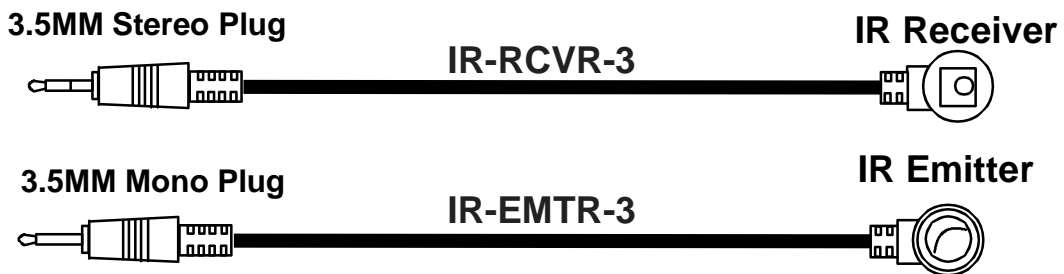

Figure 5- Connect IR Emitter and Receiver

PLUG-IN AND BOOT UP

1. Plug the power cord from each video device and the power supply for each audio device into a power outlet.
2. Connect the **24VDC 2.5A AC** adapter power connector to the power port on the VOPEX (16-port models have a country-specific line cord).

No AC adapter is required at the Remote Unit. The Remote Unit will be powered through the CATx cable from the VOPEX.

3. Plug the AC adapter/power cord into a power outlet. The green LED on the VOPEX and the green LED on the RJ45 connector of each XTENDEX Remote Unit should illuminate, indicating that a proper power connection has been made to them. (See Figure 4)

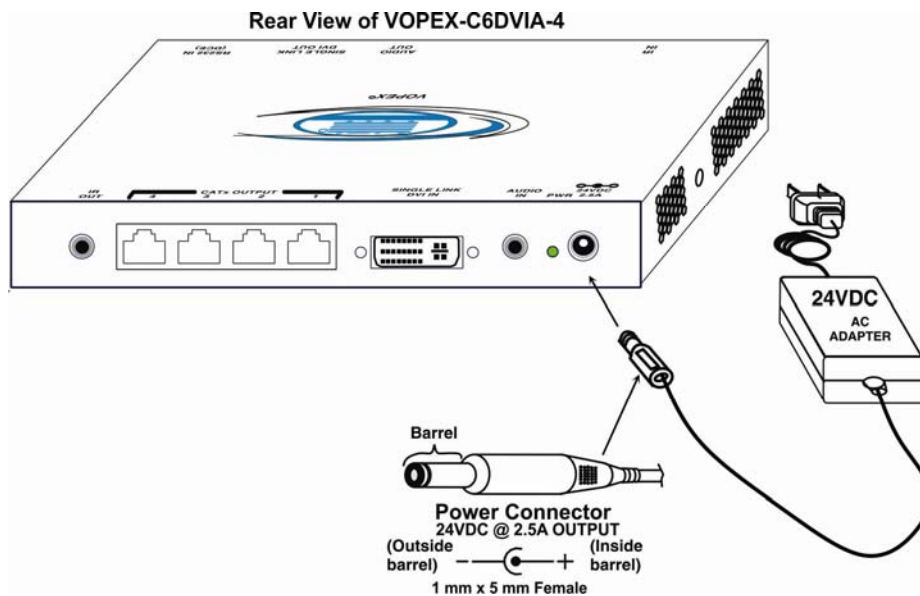

Figure 6- Connect the AC adapter to a VOPEX

4. Turn ON the audio and video source(s), stereo speakers, and monitors. They should react as if they were directly connected to each other.

Note: The yellow LED on the RJ45 connector of each XTENDEX Remote Unit will illuminate anytime data traffic is passing between the VOPEX and the XTENDEX, indicating proper CATX cable connection and communication. (See Figure 4)

CASCADING

The VOPEX-C6DVI-LA-x can be cascaded for larger configurations and greater flexibility. By connecting the “DVI Video Out” port (models with Local Access feature only) on one VOPEX with the “DVI-Video In” port on another VOPEX (4, 8, or 16 port, doesn’t matter what size), your configuration can increase in size with a minimum of effort. Models with audio support can have the audio from your source expanded in the same fashion. Connect as many or as few extenders as your cascaded configuration allows.

Note: Only models with the Local Access feature have the flexibility of being cascaded, but the VOPEX at the end does not require the Local Access feature to receive and extend the video/audio signals (as seen in the image below).

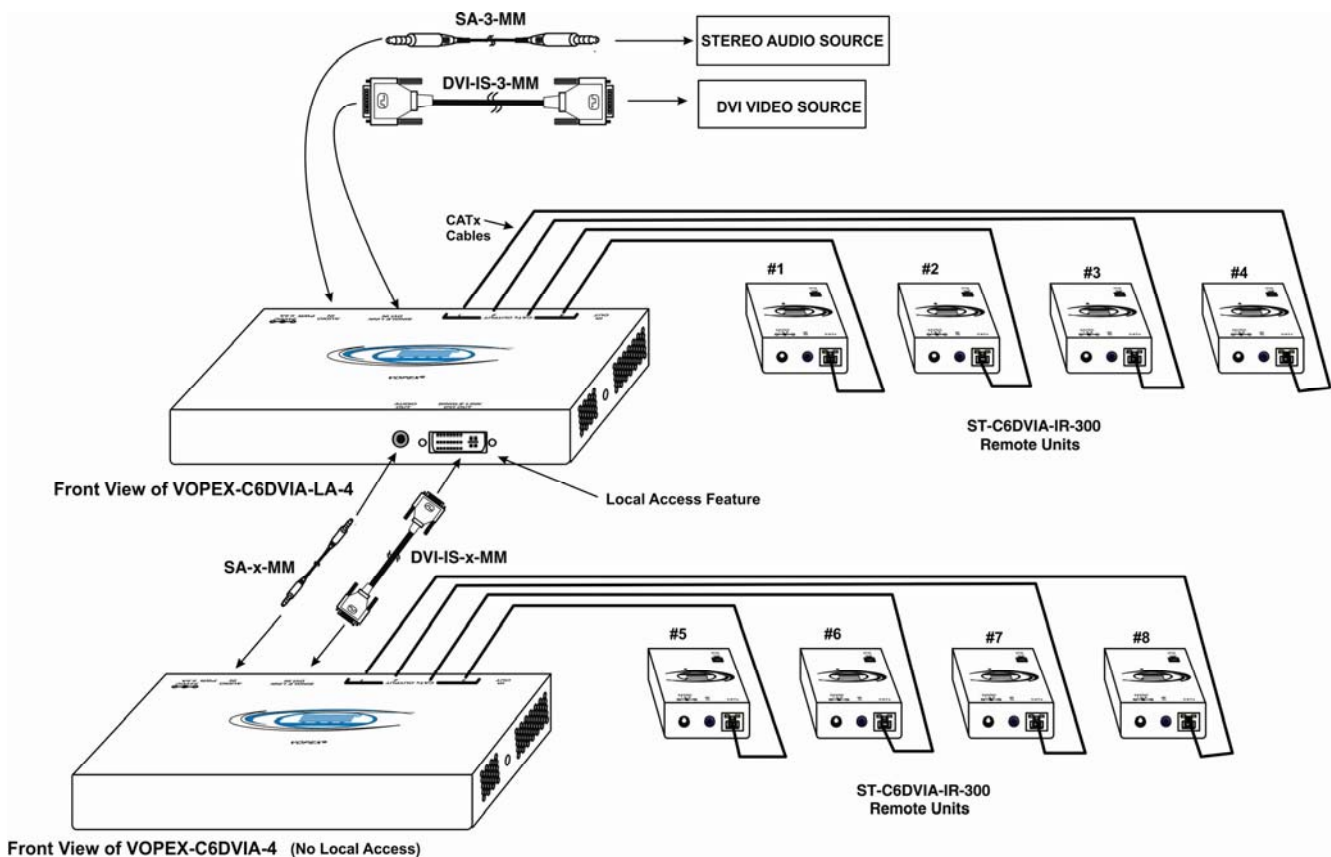

Figure 7- Cascaded VOPEX configuration

TECHNICAL SPECIFICATIONS

Video	
Video Compatibility	PC Resolution up to 1920x1200 @60Hz / HDTV resolution up to 1080p
Video Connectors	DVI Female
Input Video Signal	TMDS
Video Color Format	Up to 36 bit
DVI Support	DVI 1.0
DDC Support	DDC2b
HDCP Version	HDCP 1.2
Audio	
Audio Connectors	3.5mm stereo jack
Signal Type	Line Level, stereo, unbalanced
Audio Frequency Response	20Hz to 20KHz, \pm 1dB
Signal-to-noise ratio	76 dBA
Stereo Crosstalk	-70 dB
Audio Maximum I/O Levels	3.1Vp-p
Output Impedance	Max 2K Ohms, unbalanced
THD+N	0.017%, F=20-20KHz, RL=2K Ohm, Vout=1 Vrms
IR	
Input/Output	3.5mm Stereo Jack
Signal Type	TTL, 0-5VDC
Input Impedance	1.5 kohm
Output Impedance	33 ohm
Frequency Range	30-60kHz
Maximum Distance (from Remote Unit)	10 feet, straight; 5 feet at 45 degree angle
General	
Interconnect Cable	CAT5e solid/stranded UTP (350MHz or better); CAT6/6a Solid UTP; CAT7 Solid /Stranded STP EIA/TIA 568B wiring with male RJ45 connectors
Operating Temperature	32°F to 122°F (0°C to 50°C)
Operating Humidity Range	5 to 90% non-condensing RH
Storage temperature	-20 to 140°F (-30 to 60°C)
Power – 4/8 port models	100V to 240VAC at 50 or 60Hz-24VDC/2.5A via AC Adapter
Power-16 port models	100V to 240VAC at 50 or 60Hz via country-specific line cord
Enclosure type	Electro-galvanized steel black powder coated
Size (In.) WxDxH	4-port: 7.35x4.98x1.09 8-port: 7.35x4.98x1.68 16-port: 16.50x7.82x1.70
Compliance Certifications	CE, RoHS

**Distances and Resolutions for CAT5e,CAT6, CAT6a and CAT7 Cables
Solid and Stranded Unshielded (UTP) and Shielded (STP) Twisted Pair Resolutions**

Cable	Length ft.	Max. Resolution
CAT5e Solid UTP	100	1080p / 24Hz 1920x1200/ 60Hz 1080i / 60Hz 720p / 60Hz / 12-bit
		CAT5e Stranded UTP
CAT6 Solid UTP	50	1080p / 60Hz 1920x1200 / 60Hz
	75	1080p / 60Hz 1080i / 60Hz 1920x1200 / 60Hz
	150	1080p / 60Hz 1600x1200/ 60Hz 1080i / 60Hz
	200	1080p / 24Hz 1360x768/ 60Hz 1080i / 60Hz 720p / 60Hz
	250	1080p / 24Hz 1080i / 60Hz 480p / 60Hz
	300	480p / 60Hz 800x600 / 75Hz
CAT6a Solid UTP	50	1080p / 60Hz 1920x1200 / 60Hz
	75	1080p / 60Hz 1920x1200 / 60Hz 1080i / 60Hz
	100	1080p / 60Hz 1920x1200 / 60Hz 1080i / 60Hz
	250	1080i / 60Hz 1024x768/ 60Hz 480p / 60Hz
	300	480p / 60Hz 1024x768/ 60Hz
Flat CAT7 Stranded STP	50	1080p / 60Hz 1920x1200 / 60Hz
	100	1080i / 60Hz 1920x1200 / 60Hz
CAT7 Solid STP	200	1080p / 60Hz 1024x768/ 60Hz 1080i / 60Hz
	279	1080p / 24Hz 1024x768/ 60Hz 1080i / 60Hz 480p / 60Hz

Note: Results may vary depending on cable and/or display quality

INTERCONNECTION CABLE WIRING METHOD

The connection cable between the VOPEX and each XTENDEX Remote Unit is terminated with RJ45 connectors and must be wired according to the EIA/TIA 568B industry standard. Wiring is as per the table and drawing below.

RJ45 Connector Wiring

Pin	Wire Color	Pair	Function
1	White/Orange	2	T
2	Orange	2	R
3	White/Green	3	T
4	Blue	1	R
5	White/Blue	1	T
6	Green	3	R
7	White/Brown	4	T
8	Brown	4	R

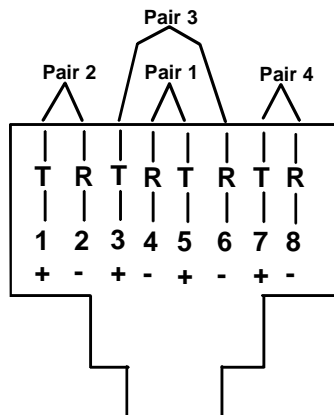

Figure 8- View looking into RJ45 female

Note: CATx connection cable used between NTI XTENDEX Series Local and Remote or any XTENDEX Series products should not be run underground, outdoors or between buildings.



WARNING: Outdoor or underground runs of CATx cable could be dangerous and will void the warranty.

TROUBLESHOOTING

Each and every piece of every product produced by Network Technologies Inc is 100% tested to exacting specifications. We make every effort to insure trouble-free installation and operation of our products. If problems are experienced while installing this product, please look over the troubleshooting chart below to see if perhaps we can answer any questions that arise. If the answer is not found in the chart, a solution may be found in the knowledgebase on our website at <http://information.networktechinc.com/jive/kbindex.jspa> or please call us directly at (800) 742-8324 (800-RGB-TECH) or (330) 562-7070 and we will be happy to assist in any way we can.

Problem	Cause	Solution
VOPEX power LED does not illuminate	<ul style="list-style-type: none"> Power supply is not connected or plugged-in. 	<ul style="list-style-type: none"> Make sure the outlet is live and the AC adapter is plugged-in. Make sure DC plug / AC line cord is fully connected.
XTENDEX power LED does not illuminate	<ul style="list-style-type: none"> VOPEX is not powered ON CATx cable not connected 	<ul style="list-style-type: none"> Make sure VOPEX is ON Check that the CATx cable is snapped-in properly at each end of the cable
No video on monitor/display	<ul style="list-style-type: none"> One or more video cables is loose or disconnected. No power to the VOPEX or the XTENDEX Remote Unit. Video Cable was not attached when video source was powered-up. CATx cable is not connected. Cable is too long for the selected resolution 	<ul style="list-style-type: none"> Check all video cable connections Make sure power LEDs are illuminated for local and remote. If not, see solution for problem above. With all the cables properly connected, cycle the power to the video source. Check cable connections. Make sure they are snapped-in properly and reboot. Check Distances and Resolutions chart on page 14.

Problem	Cause	Solution
<p>Monitor sometimes goes blank for an instant or the video is noisy</p>	<ul style="list-style-type: none"> • Electrical power system is very noisy, particularly the ground. • The CATx cable is not properly connected. • Cable is too long for the selected resolution 	<ul style="list-style-type: none"> • Make sure the interconnection cable is not near any power lines. • Check cable connections. Make sure they are snapped-in properly. • Check Distances and Resolutions chart on page 14.
<p>No audio</p>	<ul style="list-style-type: none"> • Audio cable is not properly plugged in • Speakers are not plugged in • CATx cable is not properly connected 	<ul style="list-style-type: none"> • Check all cable connections • Verify speakers are powered (if applicable) • Check CATx cable connections

WARRANTY INFORMATION

The warranty period on this product (parts and labor) is two (2) years from the date of purchase. Please contact Network Technologies Inc at **(800) 742-8324** (800-RGB-TECH) or **(330) 562-7070** or visit our website at <http://www.networktechinc.com> for information regarding repairs and/or returns. A return authorization number is required for all repairs/returns.

Manual 151 Rev. 1/14/13